

7. OPTIONAL EQ.

**7. 0. MISC.
NO-TILL COULTER
CLOD REMOVERS
RESIDUE MANAGER
NO-TILL LINKAGE**

7. 1. ROW MARKERS

7. 2. AIR INSECTICIDE

7. 4. MICROSEM INSECTICIDE

7. 5. DRY FERTILIZER

7. 7. LIQUID FERTILIZER

OPTIONAL EQUIPMENT

NO TILL COULTER

Unit Mounted

YL-527

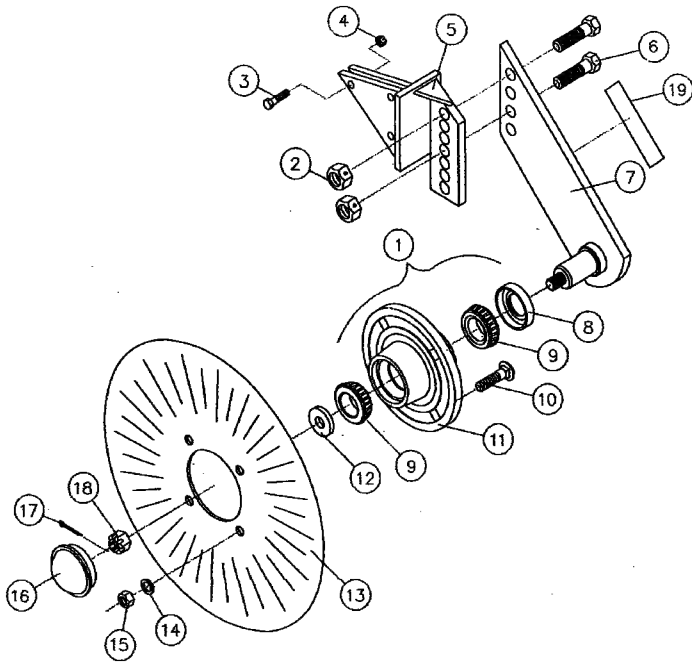

ITEM PART #	DESCRIPTION
1 Y2900-102	Hub Sub Assembly
2 Y2520-459	Lock Hex Nut 5/8 - 11
3 H-3130	Hex Head Bolt, 3/8 -16 x 1 3/4 GRD 8
4 N-2300	Lock Nut 3/8 - 16
5 L527-101	Unit Mount Bracket
6 H-5130	Hex Head Bolt, 5/8 -11 x 1 3/4 GR 8
7 L527-100	Coulter Arm
8 Y2550-115	Seal
9 Y2550-027	Cone, LM67048
10 Y2505-339	Carriage Head Bolt, 1/2 -13 GR 5
11 Y2900-105	Hub Pressed Assembly
12 Y2526-449	5/8 Flatwasher, 1/4 Thick
13 Y2571-166	25 Flute Blade, .157 x 14.56"
14 W-4610	Lock Washer, 1/2"
15 N-4001	Hex Nut, 1/2 - 13
16 Y2570-375	Hub Cap
17 Y2531-102	Cotter Pin, 1/8 x 1 1/4
18 Y2502-469	Castle Hex Nut, 5/8 - 18
19 Y2565-162	Decal

SPACERS

Front and Rear Spacers are used to hang accessories from a 2" x 2" diamond toolbar. The spacers are mounted on the 5" x 5" main frame toolbar.

PART No.	DESCRIPTION
900034.2	Front spacer, 2" x 2" Diamond bar for 7 x 7 planter.
900033.1	Rear spacer, 2" x 2" Diamond bar for 7 x 7 planter.

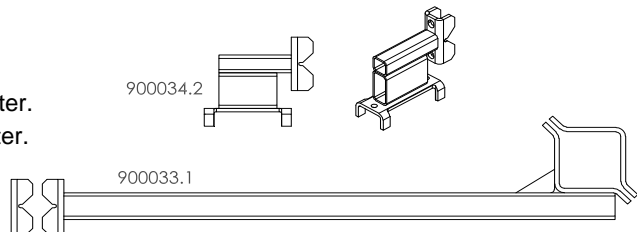

CLOD REMOVERS

The function of the clod remover is to clear the surface of the soil, but not plow a furrow. It is rigid and mounted in front of the disc openers that push clods away in preparation for the seed trench. The front brace of the clod remover is an independent adjustable opening knife that used to slice open hard soil and move stones away from the track of the disc opener. The clod remover should be adjusted according to soil type.

PART No.	DESCRIPTION
7101	Front point, clod remover
7102a	Mounting bracket, clod remover
7103a	Clod remover
HM-41035	Bolt , 10x35mm
HM-61230	Bolt , 12x30mm
NM-21015	Nylock 10mm
65034059	Clod remover brkt. Pin NG+4
66005863	Clod remover Mtg. brkt. NG+4
66005252	Clod remover adj. brace. NG+4
650996	Complete clod remover

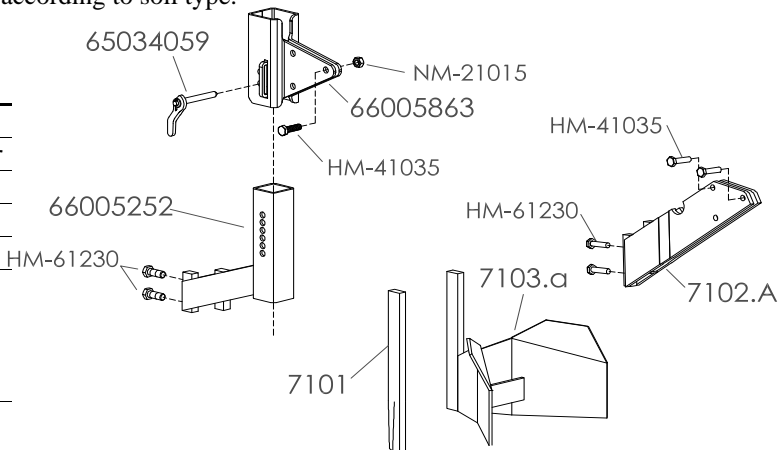

OPTIONAL EQUIPMENT

RESIDUE MANAGER

Residue managers are available for minimum and no-till situations.

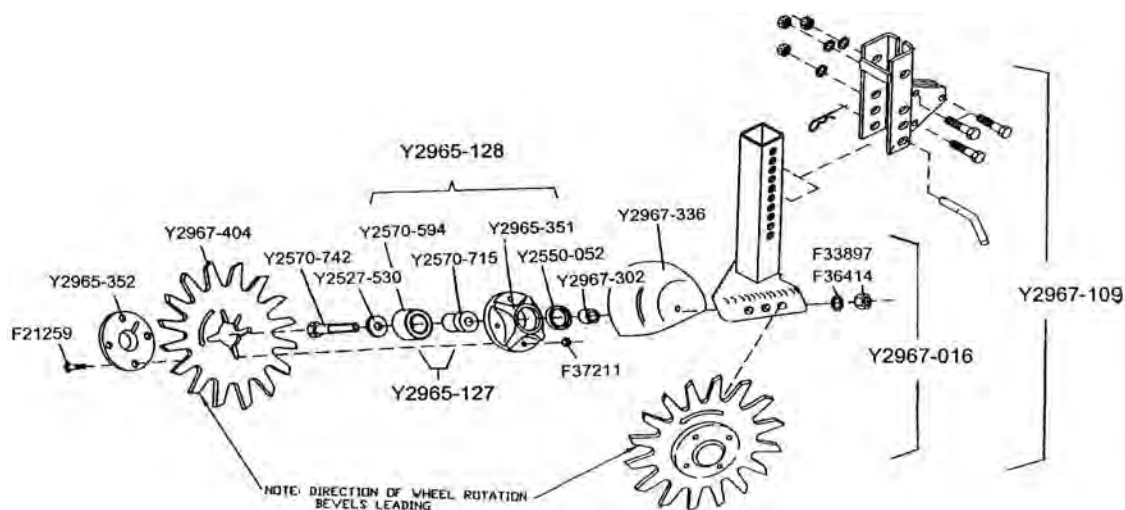

PART No.	DESCRIPTION
Y2967-109	Residue manager assy complete w/ mnt bracket

H-3130	Bolt, 3/8 -16 x 1 3/4 Gr. 5
H-4120	Bolt, 1/2- 13 x 1 1/2 Gr. 5
H-4320	Bolt, 1/2- 13 x 3 1/2 Gr. 5
CB-1150	Carriage bolt, 5/16 -18 x 1 1/2 Gr. 5
W-4210	Flat washer, 1/2
W-2610	Lockwasher, 3/8
W-5610	Lockwasher, 5/8"
N-2001	Nut 3/8- 16
N-5001	Nut, 5/8- 11
N-1101	Rev lock nut, 5/16- 18
N-4101	Rev lock nut, 1/2- 13
Y2526-402	Machine bushing, 9/16 ID x 1 3/4 OD x 1 1/4
Y2527-530	Machine bushing, 3/16"
Y2550-052	Seal for hub and bearing
Y2570-448	Hairpin, 1/8"
Y2967-404	Spoke wheel, 13" dia
Y2570-594	Bearing
Y2570-715	Insert for bearing
Y2570-742	D bolt, 5/8- 11 x 4" Gr. 5
Y2965-127	Bearing and insert assy
Y2965-128	Hub and bearing assy
Y2965-305	Pin
Y2965-351	Hub
Y2965-352	Hub cap
Y2967-016	Residue manager assu less mounting bracket
Y2967-200	Stem
Y2967-211	Mounting bracket for No-till parallel linkage
Y2967-245	Mounting bracket only
Y2967-302	Spacer, 3/4"
Y2967-336	Bearing shield

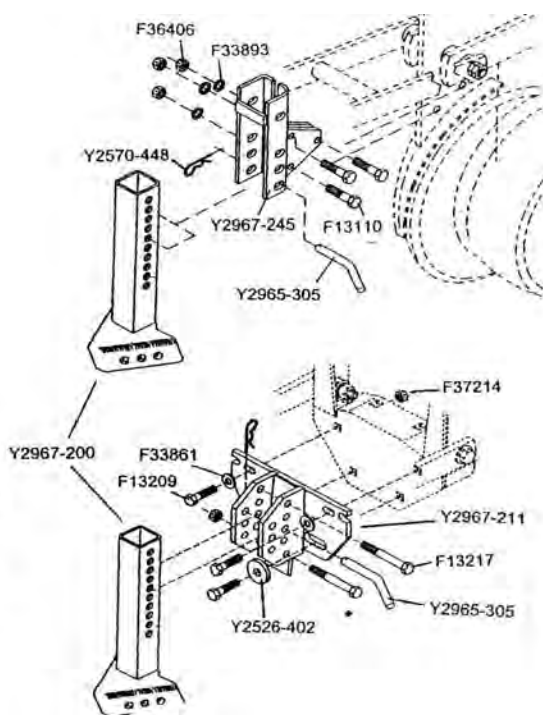

PART No.	DESCRIPTION
5	Y2967-234 Single Wheel Arm WA
7	Y2525-352 1/2 Medium Lockwasher ZP
8	Y2505-339 1/2- 13 x 1 1/2 Car. Clt GR 5 ZP
9	Y2967-405 Wheel Mount
10	Y2520-352 1/2- 13 Hex nut ZP

OPTIONAL EQUIPMENT

7" X 7" No Till Linkage

ASSEMBLY

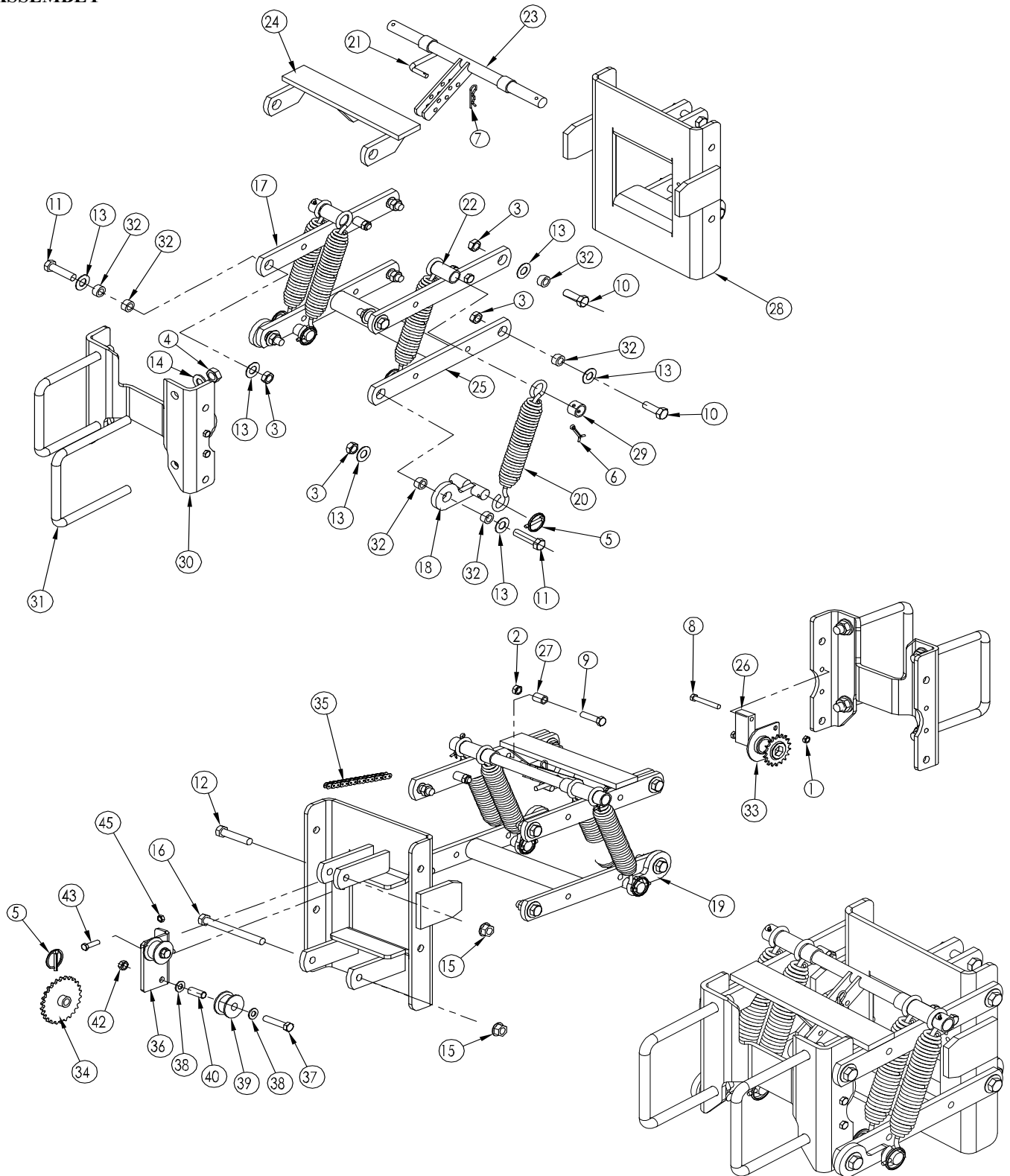

OPTIONAL EQUIPMENT

7" X 7" No Till Linkage

ASSEMBLY

ITEM	PART No.	DESCRIPTION
1	N-2100	3/8-16 Nylock nut Gr 5
2	N-4101	1/2-13 Nylock nut Gr 8
3	N-5101	5/8-11 Nylock nut Gr 8
4	N-6101	3/4-10 Nylock nut Gr 8
5	6077	Lynch pin, 1/4 x 1 1/4
6	F65147	Cotter pin, 1/4 x 2
7	7091	Hairpin, 1/8
8	H-3230	Hex bolt, 3/8-16 x 2 3/4 Gr 8
9	H-4220	Hex bolt, 1/2-13 x 2-1/2 Gr 8
10	H-5201	Hex bolt, 5/8-11 x 2 Gr 8
11	H-5301	Hex bolt, 5/8-11 x 3 Gr 8
12	H-5301	Hex bolt, 5/8-11 x 3 Gr 8
13	W-5210	Flat washer 5/8 Gr 8
14	W-6210	Flat washer 3/4 Gr 8
15	N-5401	Nut, flange head 5/8-11
16	H-5651	Hex bolt, 5/8-11 x 6 1/2 Gr 8
17	907097	Upper Parallel arm
18	L124591	Spring anchor LH
19	L124592	Spring anchor RH
20	L124630	Spring w/swivel hooks
21	L124643	Pin, spring adjustment
22	L124645	Spacer
23	907067	Spring bar
24	907130	Front bar
25	907098	Lower parallel arm
26	906972	Spacer block for sprocket
27	L124709	Spacer bushing
28	907064	Baseplate for unit mount
29	L125007	Bushing with hole for cotter pin
30	906967	Mounting plate, to toolbar
31	4502.SA	U-bolt, 7 x 7 x 3/4
32	L71505214	Bushing 5/8" ID x 1" OD x 37/64" wide
33	KA1720	Bearing sprocket
34	7110.S	Sprocket, 27 tooth #41 chain
35	900259	Chain, #41 x 124 links
36	800310	Roller bracket
37	H-4220	Hex bolt, 1/2-13 x 2 1/2 Gr 8
38	W-4410	Flat washer, 1/2
39	KD0916	Chain roller
40	E7523.1	Bushing, 13 ID x 16 OD x 38mm
42	N-4301	Reversible lock nut, 1/2-13
43	H-3104	Hex bolt, 3/8-16 x 1 1/4
45	N-2101	3/8-16 Nylock nut Gr 8
L124846		Linkage and spring kit (less sprocket, chain and rollers)
800310.ASY		Idler assembly (items 36 - 45)

ROW MARKERS

Pull-Type Rigid Frame

ROW MARKER ADJUSTMENTS

The row marker length is determined by multiplying the number of rows by the row spacing (in inches). This figure should be equal to the distance from the end of the marker blade to the center line of the planter. Both the planter and the marker assembly should be lowered to the ground when measurements are taken. The measurement should be taken from the point where the blade contacts the ground. Adjust the left and right row markers equally to the determined length and securely tighten the clamping bolts.

Example:

of Rows x Row Spacing (inches) = Dimension
between Planter Center line and
Marker Disc Blade.

6 rows x 30" row spacing = 180".

Row marker extension from center of planter to end of row marker blade should be 180".



WARNING To avoid injury, stand clear and keep others away when raising or lowering markers. Lock row markers for transport using the locking sleeve or locking pin.



WARNING Use extreme care when operating the row markers near electrical lines.



WARNING
Hydraulic fluid escaping under pressure can penetrate the skin causing serious injury. Relieve pressure before disconnecting hydraulic lines. Tighten connections before applying pressure. If injured by escaping hydraulic fluid see a doctor at once. Gangrene can result. Wear proper hand and eye protection when searching for leaks. Use wood or cardboard instead of hands.



MARKER SPEED ADJUSTMENT

Markers come standard with automatic sequence valves. A flow control valve controls the lowering and raising speed of the markers. To slow the marker travel speed, loosen the jam nut and turn the control clockwise, or in. Turn the control counterclockwise, or out, to increase the travel speed. The adjusting bolt determines the amount of oil flow restriction through the flow control valve, therefore determining travel speed of the markers.



DANGER: Properly adjust the flow controls before the marker assembly is first put into use. Excessive travel speed of the markers can be dangerous and/or damage the marker assembly.

NOTE: When oil is cold, hydraulics operate slowly. Make sure all adjustments are made with warm oil.

NOTE: On a tractor where the oil flow can not be controlled, the rate of flow of oil from the tractor may be greater than the rate at which the marker cylinder can accept it. The tractor hydraulic control lever will have to be held until the cylinder reaches the end of its stroke. This occurs most often on tractors with an open center hydraulic system.

On tractors with a closed center hydraulic system, the tractor's hydraulic flow control can be set so the tractor's detent will function properly.

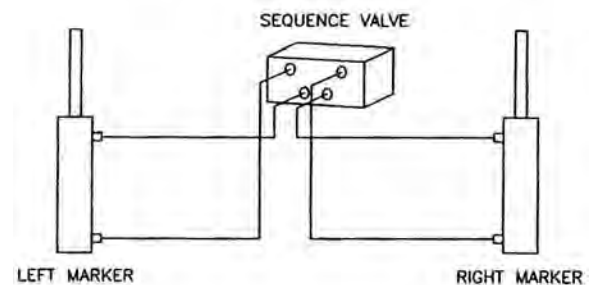
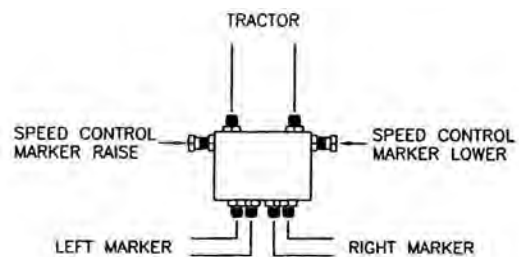

Single central marker sequence valve

ROW MARKERS

Pull-Type Rigid Frame

VALVE BLOCK INSPECTION

The valve block assembly consists of the marker sequencing and flow control valves in one assembly. The sequencing valve consists of a chambered body containing a spool and series of check valves to direct hydraulic oil flow. Should the valve malfunction, the components may be removed for inspection as follows:

1. Remove valve block assembly from planter.
2. Remove detent assembly and port adapter assemblies from rear of valve block.
3. Remove plug from both sides of valve block and remove spool.
4. Inspect all parts for pitting, contamination or foreign material. Also check seating surfaces inside the valve. Replace any parts found to be defective.
5. Lubricate spool with a light oil and reinstall. Check to be sure spool moves freely in valve body.

Important: Make sure the correct check ball(s) and spring are installed in each valve bore before reassembly.

HYDRAULIC MARKER SYSTEM– Single Valve

With the single valve marker system, both markers can be used at the same time by first lowering the marker and moving the hydraulic control lever to the raise position and immediately returning it to the lower position. This will shift the marker control valve spool and the remaining marker will be lowered. This is useful in planting contours and terraces.

An additional control is required for the optional lift assist package unless it is tied into the tractor 3-point lift system. Check with your tractor dealer for parts required.

 **WARNING** Always stand clear of marker assemblies and blades when planter is operating.

 **WARNING** Always position lockups in “Safety” position when transporting or storing planter.

 **DANGER** If a marker or wing lift cylinder has been removed for any reason, do not attach the rod end of the cylinder until the cylinder is cycled several times to remove any air that may be trapped in the system.

 **DANGER** Serious injury or death can result from contact with electric lines. Use care to avoid contact with electric lines when moving or operating this machine.

HYDRAULIC MARKER SYSTEM -Single Valve

ASSEMBLY

(See Page 3.6 in Frame Section for Hydraulic System Diagram)

TROUBLESHOOTING

If both markers are lowering, but only one is raising at a time

- The hoses from the cylinders to the valve may be connected backwards. Check the hose diagram in manual to correct.

If the same marker is always operating,

- The spool in sequencing valve may not be shifting. Remove spool and inspect for foreign material to make sure all ports in the spool are open. Clean spool and reinstall.

If both markers lower and raise at the same time

- There may be foreign material under the check ball in the sequencing valve. Remove and clean the hose fitting, spring and balls. Remove and clean the spool as well.
- Make sure there is not a ball missing or incorrectly installed in the sequencing valve. Disassemble and correct if this is the case.

Increase hydraulic flow, spool may not be shifting.

If the marker is setting down while in the raised position,

- The O-ring in the marker cylinder may be damaged or the piston may be cracked. Disassemble the cylinder to inspect for damage, repair any damage.
- The spool in sequencing valve may not be shifting completely because of a detent ball or because the spring is missing. Check the valve assembly and install parts as needed.
- The spool in sequencing valve may be shifting back towards the center position. Restrict the flow of hydraulic oil from the tractor to the sequencing valve.

If neither marker will move

- The flow control may be closed too much. Loosen the locking nut and turn the flow control adjustment bolt out, or counterclockwise, until the desired speed is set.

If the markers are moving too fast

- The flow control may be open too much. Loosen the locking nut and turn the flow control adjustment bolt in, or clockwise, until the desired speed is set.

If the marker operation speed is sporadically changing

- The needle may be sticking open in the flow control valve. Remove the flow control, inspect and repair or replace.

ROW MARKERS

Pull-Type Rigid Frame

Marker Sequencing Flow Control Valve

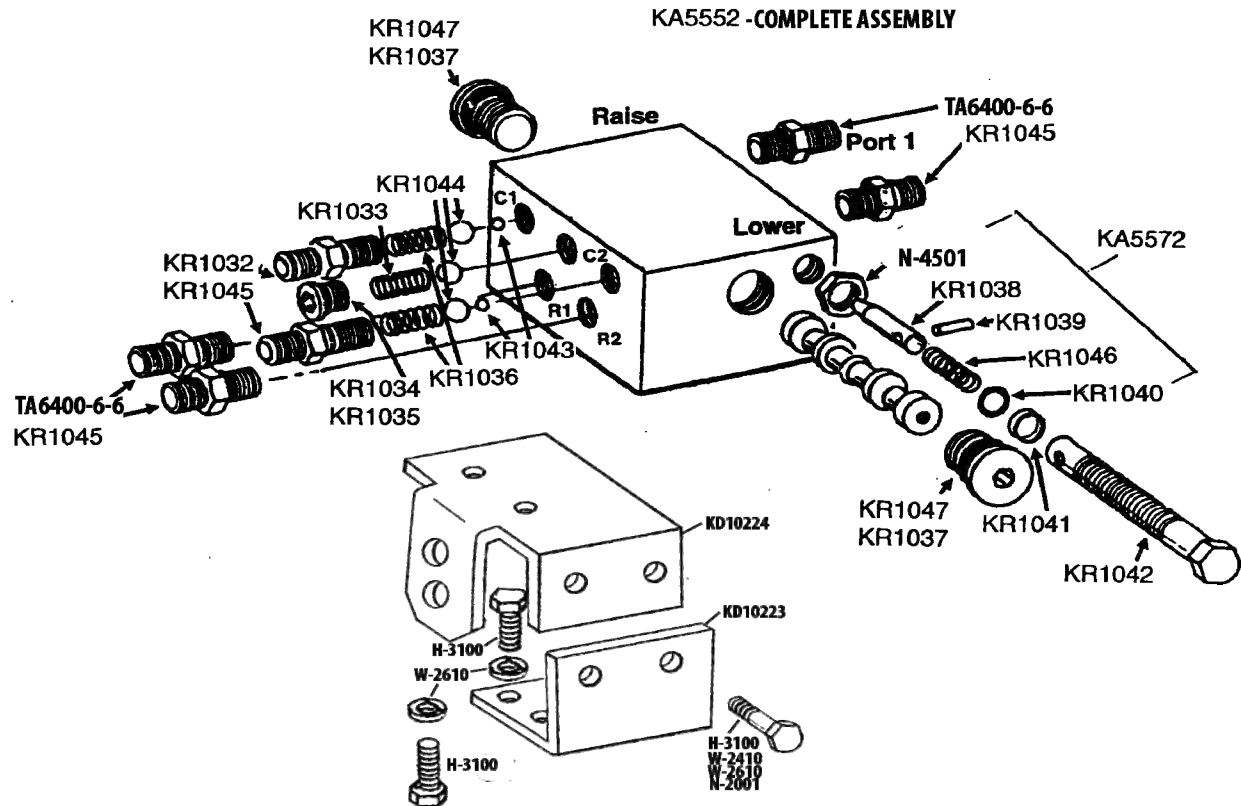

PART No.	DESCRIPTION
KA5552	Valve assembly complete
KA5572	Flow control portion only
H-3100	Hex head Bolt, 3/8" -16x 1"
W-2410	Washer, 3/8" SAE
W-2610	Lock washer 3/8"
TA6400-6-6	Connector with O-ring, 9/16" -18 male 37 JIC to 9/16" -18 O-ring
KR1032	Port adaptor with O-ring
KR1033	Detent spring
KR1034	Hex socket O-ring plug w/ O-ring
KR1035	O-ring
KR1036	Spring
KR1037	O-ring
KR1038	Needle
KR1039	Spring pin
KR1040	O-ring
KR1041	Teflon BU ring
KR1042	Adjustment screw
KR1043	1/4" steel ball
KR1044	7/16" check ball
KR1045	O-ring
KR1046	Compression spring
KR1047	Hex socket plug with O-ring
N-4501	Hex jam nut, 1/2" -20
N-2001	Nut, 3/8"
KD10223	Mounting Angle
KD10224	Valve Mounting Angle

ROW MARKERS

Pull-Type Rigid Frame

Marker Spindle / Hub / Blade

The marker blade is installed so the concave side of the blade is outward to throw dirt away from the grease seals. The spindle bracket is slotted so the hub and blade can be angled to throw more or less dirt. To adjust the hub and spindle, loosen the hardware and move the bracket as required. Tighten the bolts to the specified torque.

IMPORTANT: A marker blade assembly that is set at a sharper angle than necessary will add unnecessary stress to the complete marker assembly and shorten the life of bearings and blades. Set the blade angle only as needed to leave a clear mark.

A field test is recommended to ensure the markers are properly adjusted. After the field test is made, make any minor adjustments necessary.

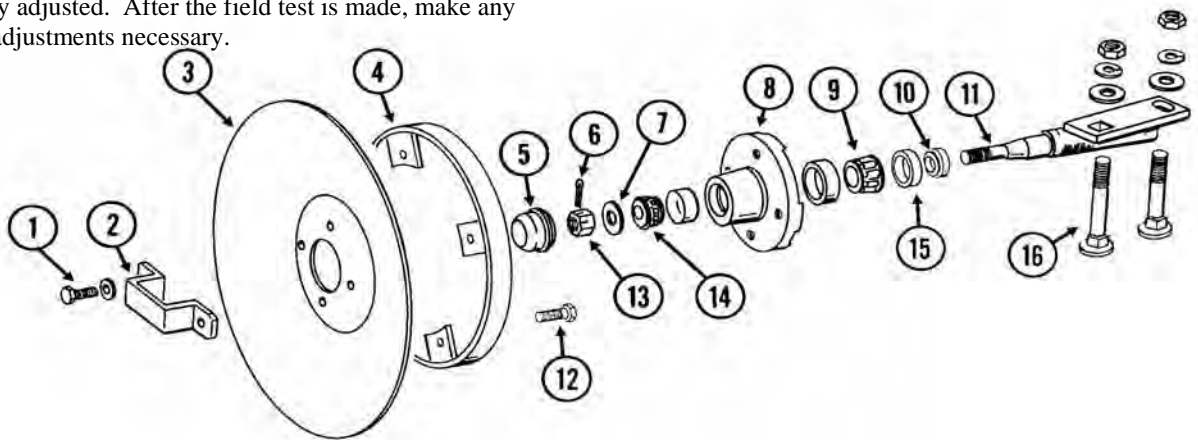

ITEM	PART No.	DESCRIPTION
1	K10722	Hex head cap screw, 1/2" -20x 1"
	W-5610	Lock washer, 1/2"
2	KD2597	Retainer
3	KD0746	Solid blade, 16" (shown)
	KD10283	Notched blade, 16" (Optional)
4	KA5853	Depth band
5	KD0840	Dust cap
6	K10544	Cotter pin, 5/32" x 1"
7	W-5410	Washer, 5/8" SAE
8	KA0167	Hub with cups
	KR0151	Outer cup
	KR0150	Inner cup
9	KA0245	Inner bearing
10	KA0899	Rubber seal
11	KA1676	Spindle, righthand
	KA1677	Spindle, lefthand
12	H-2100	Hex head cap screw, 5/16" -18x 1"
	K10109	Lock nut, 5/16"-18, grade 8
13	K10725	Hex slotted nut, 5/8" -18
14	KA0257	Outer bearing

15	KA0243	Grease seal
16	K10844	Carriage bolt, 1/2" -13x 3 1/2"
	K10168	Machine bushing, 1/2", 7 gauge
	W-4610	Lock washer, 1/2"
	N-4000	Hex nut, 1/2" -13
A.	KA1678	Hub and spindle assy, RH
	KA1679	Hub and spindle assy, LH
(Items 1, 2, 5-11, and 13-15)		

ROW MARKERS

Pull-Type Rigid Frame

7" x 7" Single Fold Row Marker

ASSEMBLY

ITEM	PART No.	DESCRIPTION
1	KD0453-02	Extension tube 4R30
	KD0453-07	Extension tube 4RW/6R30
2	KD2721	U bolt, 2" x 2"x 1/2 -13
	K10228	Lock washer, 1/2"
	K10102	Hex nut, 1/2" -13
3	KA5175	Arm 4R30
	KA5184	Arm 4RW
	KA5183	Arm 6R30
	K10640	Grease fitting, 1/4" -28
4	KD0462	Safety lockup pin
	K10670	Hair pin clip, No. 3
	K10187	Spring pin, 5/32" x 2"
5	KA5177	Mount 4R30
	KA5178	Mount 6R30
	K10640	Grease fitting, 1/4" -28
6	KD0438	Pin, 13 1/2"
	K10460	Cotter pin 1/4x2"
7	K10133	Hex head cap screw, 5/16" -18x 1 1/2"
	K10109	Lock nut, 5/16" -18
8	KD5892	Hose clamp, 5/8" x 1 1/2" x 1 1/2"
9	K10008	Hex head cap screw, 5/8" -11x 2"
	K10230	Lock washer 5/8
10	KA8919	Cylinder
11	KR0367	Pin, 2 7/8"
	KR0193	Clip
12	KR0375	Pin, 3 1/2"
	KR0193	Clip

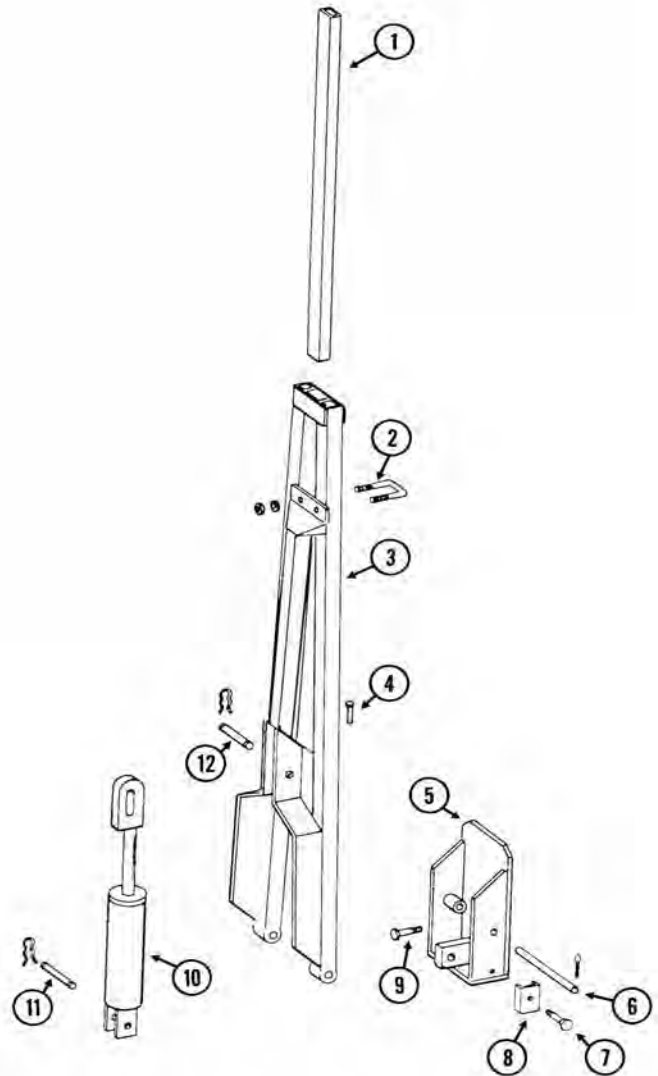

SINGLE FOLD MARKER CYLINDER

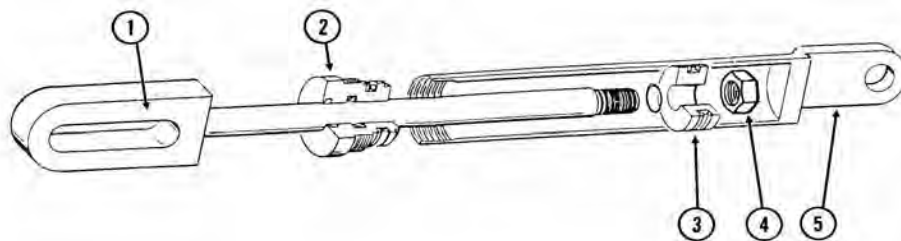

ITEM	PART No.	DESCRIPTION
	KA8919	Cylinder complete, 2" x 8"
1	KA8918	Rod assembly
2	KD12510	Gland
3	KD12511	Piston
4	K10967	Lock nut, 3/4" -16
	KR1529	Seal kit, includes 1 T seal, 2 O-rings, 1 BU ring, 1 U cup, 1 wiper

ROW MARKERS

Pull-Type Rigid Frame

7" x 7" Two Fold Row Marker

ITEM	PART No.	DESCRIPTION
1	KD0453-03	Extension tube 6RW/8R30
2	K10226	Washer, 1 1/4" SAE
3	KA5173	First stage arm w/ grease fittings
	K10641	Grease fitting, 1/8" NPT
4	KA9443	Cylinder
5	KD15386	Pin, 1 1/4" x 7 5/8"
	K10460	Cotter pin, 1/4"x 2"
6	KD5875	Hose clamp
7	K10133	Hex head cap screw, 5/16" -18x 1 1/2"
	K10109	Lock nut, 5/16" -18
8	KD0652	Pin, 1 1/4" x 9 1/2"
	K10460	Cotter pin, 1/4"x 2"
9	K10879	Flanged 12 point bolt 5/8" -11x2
10	KA5130	Mount
11	KD3214	Pin, 1 1/4" x 12 1/4"
	K10460	Cotter pin, 1/4"x 2"
12	KD2161	Pin, 1 1/4" x 8 1/4"
	K10460	Cotter pin, 1/4"x 2"
13	KD2721	U bolt, 2"x 2"x 1/2" -13
	K10228	Lock washer, 1/2"
	K10102	Hex nut, 1/2" -13
14	KA5190	Second stage arm 6R36/38
	KA5188	Second stage arm 8R30
15	KD0752-41	Sleeve 1" (if applicable)

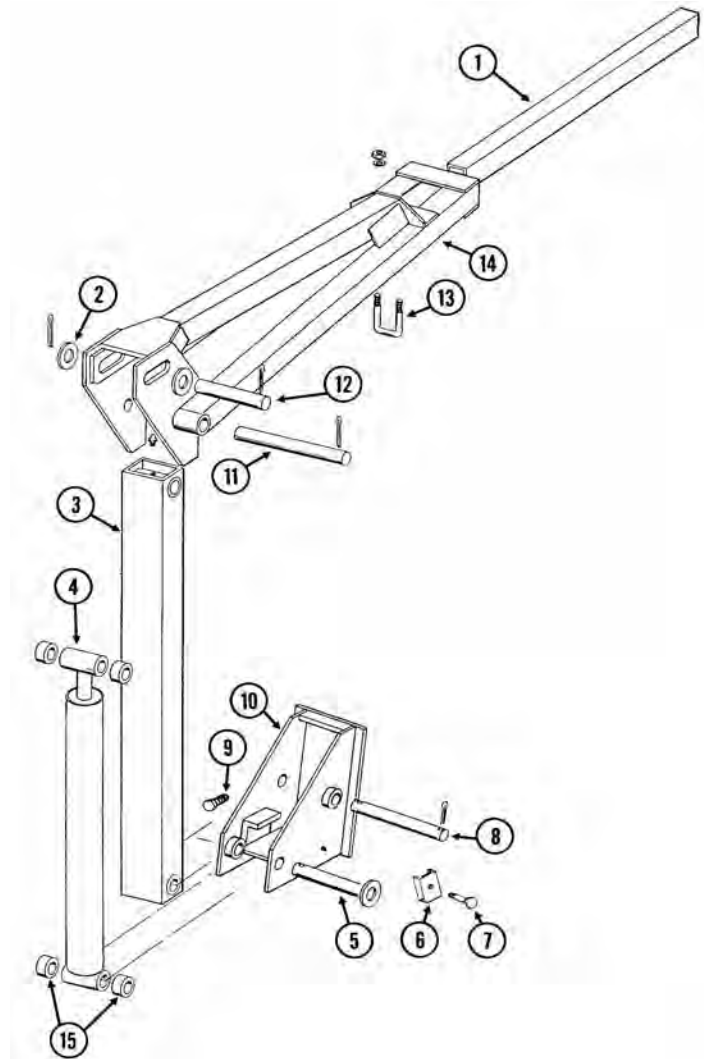

TWO FOLD MARKER CYLINDER

3/4" - 16 O-Ring Ports

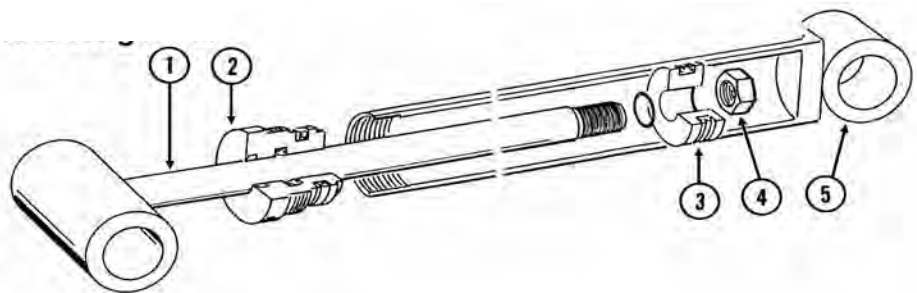

ITEM	PART No.	DESCRIPTION
	KA9443	Cylinder complete, 2" x 20 1/16"
	KA9440	Rod assembly
	KD12510	Gland
3	KD12511	Piston
4	K10967	Lock nut, 3/4" -16
	KR1529	Seal kit, includes 1 T seal, 2 O-rings, 1 BU ring, 1 U cup, 1 wiper

AIR INSECTICIDE

SYSTEM ASSEMBLY

The ¼” vacuum hose connects to the bottom port in the back of the vacuum gauge. The filter is to be used in the top port in back of the vacuum gauge. Use plugs in the side ports.

The ¼” pressure hose connects to the top port in the back of the vacuum gauge. Use the filter in the bottom port in back of the vacuum gauge. Use plugs in the side ports.

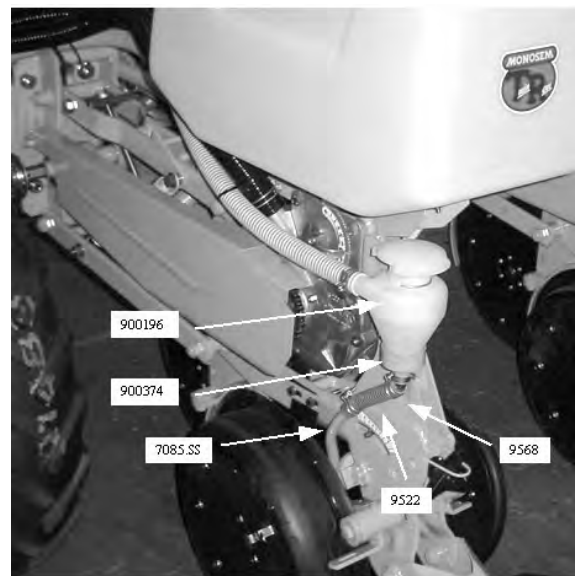
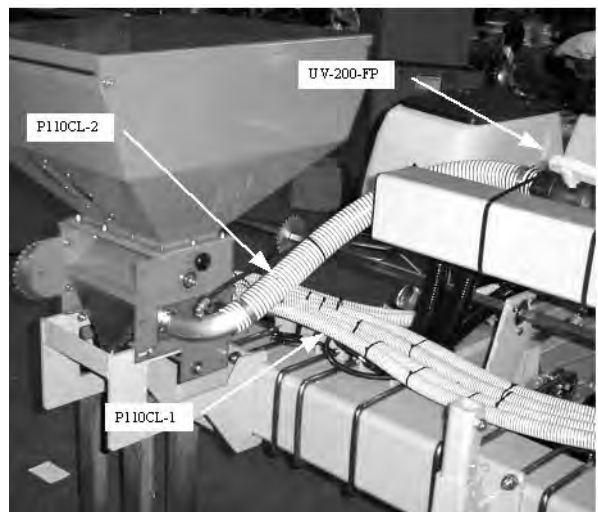
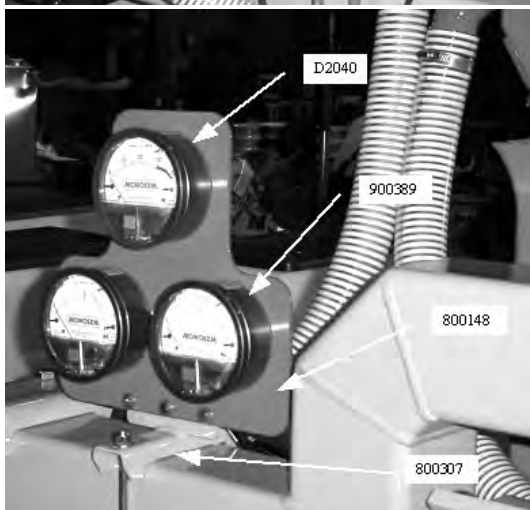
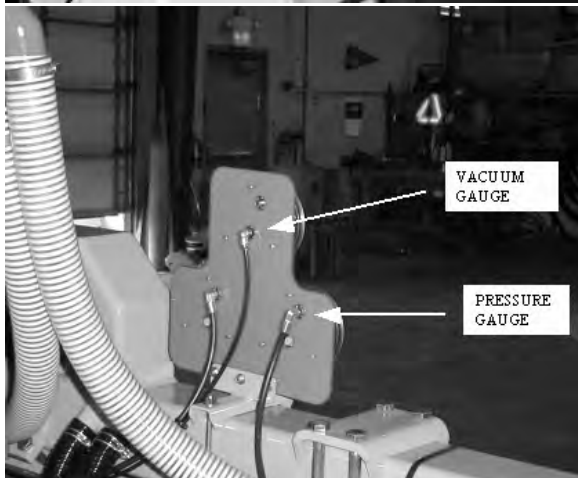
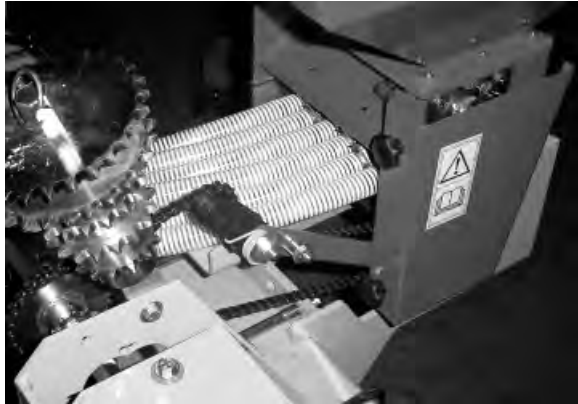

PART NO.	DESCRIPTION
D2040	Vacuum Gauge
90389	Pressure Gauge
800148	Panel Triple Gauge
800307	Bracket Gauge panel
UV-200-FP	2” Ball valve, (requires Fitting TERHB200-200, qty 2)
P110CL-2	2” Hose (Specify Length)
P110CL-1	1” Hose (Specify Length)
UV-200-FP	2” Ball valve, (requires Fitting TERHB200-200, qty 2)
P110CL-2	2” Hose (Specify Length)
P110CL-1	1” Hose (Specify Length)
900196	Cyclone (includes fitting)
900374	Cyclone clamp
7085.SS	Drop tube
9522	Hose (Specify Length)
9568	Hose Clamp

AIR INSECTICIDE

DOUBLE TURBOFAN ASSEMBLY

PART No. DESCRIPTION

4401.B	Fan housing (support frame side)
4402.C	Fan housing manifold side
4405.A	Lower shaft (1 3/8" 6 spline adapter)
4407	Bearing 62mm (62062RS)
4408	Bearing 72mm (63062RS)
4409	Snap ring internal 72mm
4410	Spacer upper shaft
4411	Spacer lower shaft
4412.B	Pulley, 500/540rpm
	Hi-Output 25 grooves 290mm dia.
4413.B	Fan belt, 25 grooves (1244JEJ151)
4437	Key lower shaft (8x7x40mm)
4439.A	Key upper shaft (6x6x45mm)
4440	Special bolt tension adjustment
4452.B	Upper shaft, 25 grooves 29mm dia.
10020595	Lower spacer segment
10020596	Upper spacer segment
10020597	Front spacer segment
10020598	Divider plate
10603010	Nut, 10mm
10603014	Nut, 14mm
10603020	Nut, 20mm
10629007	Washer, 6mm
10629009	Washer, 8mm
10629013	Washer, 12mm
20047970	Lift hook
20048560	Support bar
20048570	Belt guard
20051760	Anti vibration strap
30502016	Bolt, 12 x 25mm
30507076	Bolt, 14 x 25mm
30510099	Bolt, 6 x 40mm
30511000	Bolt, 6 x 45mm
30512021	Bolt, 10 x 50mm
30512080	Bolt, 14 x 45mm
30561061	Carriage bolt, 8 x 50mm
30561062	Carriage bolt, 8 x 55mm
30562047	Carriage bolt, 12 x 30mm
30600006	Nut, 6mm
30600008	Nut, 8mm
30600012	Nut, 12mm
30600014	Nut, 14mm
30620089	Washer, 10.5 x 20 x 2mm
30620095	Washer, 10.5 x 27 x 2mm
30621046	Washer, 13 x 27 x 2mm
30621061	Washer, 13 x 40 x 4mm
30623043	Washer, 22.5 x 48 x 4mm
30624015	Washer, 31 x 41 x 1.5mm
30624016	Washer, 31 x 41 x 2mm
40090315	Screw, 12 x 30mm
65004042	Double fan blade
66005121	Support frame
66009197	Lower bearing housing

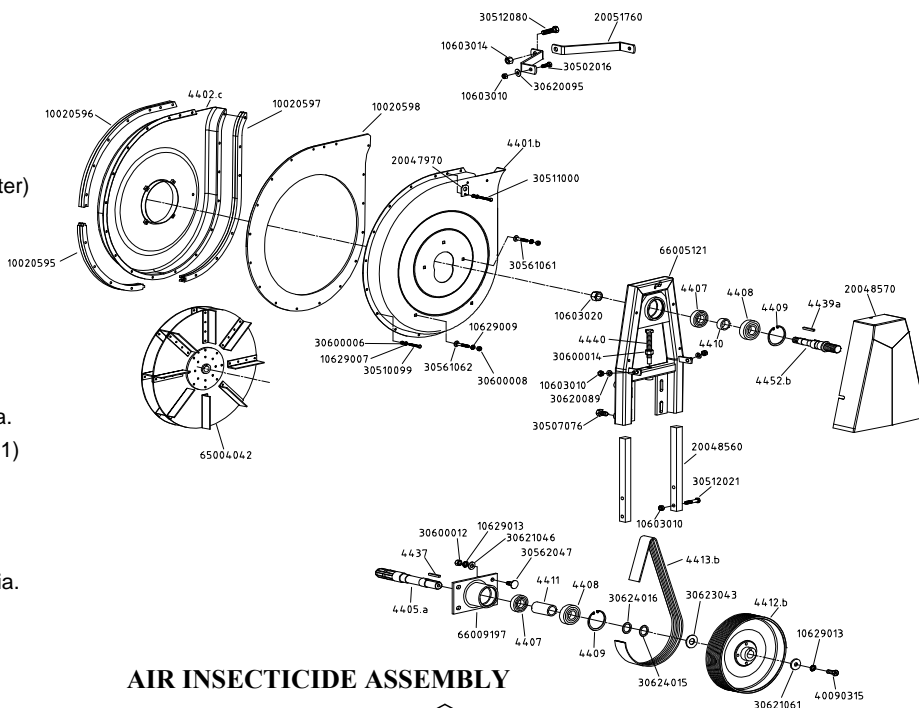

AIR INSECTICIDE ASSEMBLY

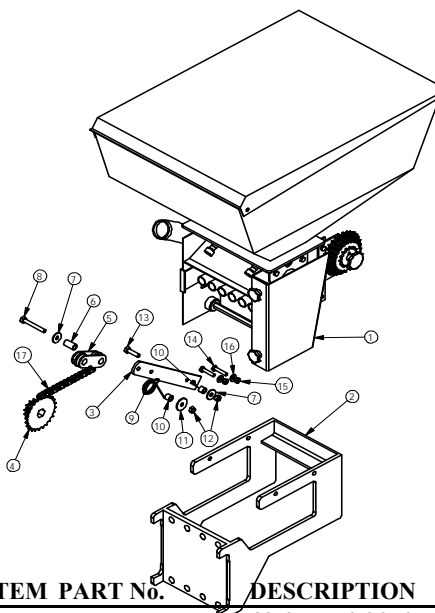

ITEM	PART No.	DESCRIPTION
1	641400	Air Insecticide hopper w/ meter
2	800261	Hopper bracket
3	800123	Idler support arm
4	9555.A	Double Sprocket 12-25
5	KD11962	Idler, US Insect
6	KD1026	Long sleeve tube
7	F33008	3/8" Flat washer
8	F15114	3/8" x 2 3/4" Bolt
9	KD9306	Spring, US Insecticide Idler
10	KD2971-10	Short sleeve tube
11	K10210	3/8" Large Flat washer
12	F37212	3/8" Center lock nut
13	F13109	3/8" x 1 1/2" Bolt
14	F13059	5/16" x 1 1/2" Bolt
15	F37211	5/16" Center lock nut
16	F33114	5/16" Flat washer

AIR INSECTICIDE SYSTEM

Twin-Row

ASSEMBLY

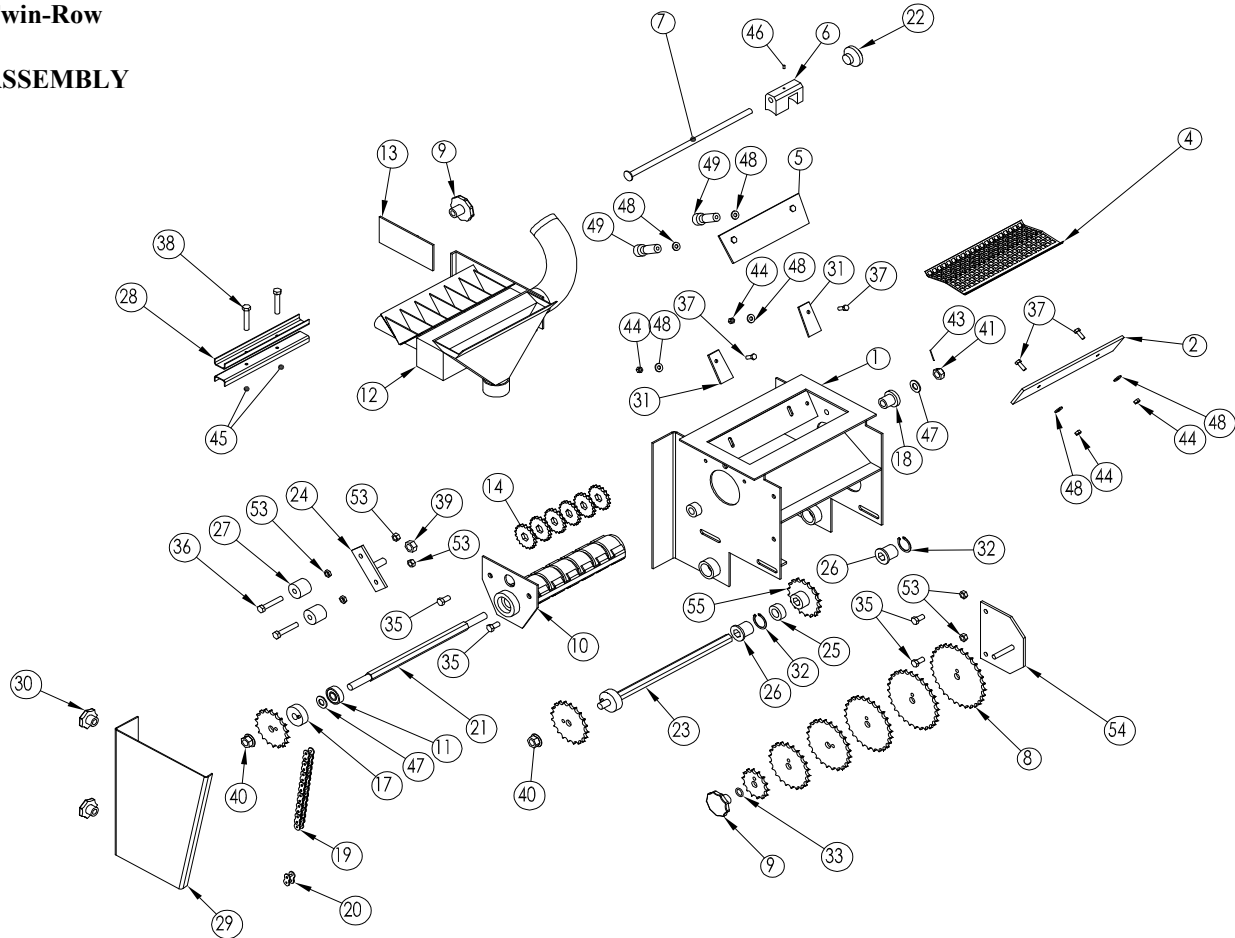

ITEM PART No.	DESCRIPTION
1	Main housing
2	Stainless steel plate
3	Guard
4	Screen
5	Clean out trapdoor
6	Shut off gate to create 4 or 6 outlet
7	Shaft for shut off gate
8	7701.14 Sprocket, 14T, 5R
	7701.16 Sprocket, 16T, 5R
	7701.18 Sprocket, 18T, 5R
	7701.20 Sprocket, 20T, 5R
	7701.22 Sprocket, 22T, 5R
	7701.24 Sprocket, 24T, 5R
	7701.26 Sprocket, 26T, 5R
	7701.28 Sprocket, 28T, 5R
	7701.30 Sprocket, 30T, 5R
27	7714 Plastic chain idler tensioner
28	Support plates for hose
29	Chain guard
30	7715 Threaded knob, 8mm
31	Corner plate for clean out door
32	7716 Snapping, external, 24mm
33	7717 O ring, 12mm ID
35	Hex bolt, 8 x 16mm
36	Hex bolt, 8 x 45mm
37	Hex bolt, 6 x 16mm
38	Hex bolt, 5 x 40mm
39	Hex nut, 12mm
40	7718 Hex nut, 12mm w/ washer

ITEM PART No.	DESCRIPTION
9	7702 Sprocket carrier w/threaded knob
10	7703 Rotor weldment
11	7704 Bearing, 6201, 12x 32x 10mm wide
12	Venturi manifold w/ 6 outlets
13	Plate with weldment, 8mm stud bolt
14	7705.5 Serrated roller, 5mm
17	7706 Hub w/ locator pin, 12 mm ID
18	7707 Plastic bushing, 12 mm ID
19	10107 Roller chain, 5R
20	10111 Connecting link, 5R
21	7708 Meter shaft, 15mm hex w/ 12mm thread
22	7709 Threaded knob, 10mm
23	7710 Hex shaft, 14mm w/ hub & locator pin
24	7711 Chain tensioner bracket
25	7712 Aluminum lock collar w/ set screw
26	7713 Plastic bushing, w/ 14 mm hex bore
41	Nylon locknut, 12mm w/ hole for roll pin
42	Set screw w/ spring loaded ball end, 6mm
43	Roll pin, 3 x 20mm
44	Hex nut, 6mm
45	Nylon locknut, 5mm
46	Set screw, 6 x 1 mm
47	Flat washer, 12 x 24 x 2mm
48	Flat washer, 6.5 x 15 x 1.5mm
49	7719 Threaded knob, 6mm
53	Hex nut, 8mm
54	Sprocket storage bracket
55	4426.18 Sprocket, 18T, bottom hex shaft

AIR INSECTICIDE SYSTEM

Twin-Row

AIR INSECTICIDE APPLICATION RATES

Double sprocket on hex shaft and changeable sprockets on 6 outlet insecticide metering boxes.

Rates are in pounds per acre

These settings are theoretical and approximate. Actual output may vary.

TEMIK 15G		Gypsum							
		Double Sprocket: 12							
		Sprockets on insecticide meter box							
Driver		14	14	14	14	28	30	22	26
Driven		30	26	22	16	30	28	18	18
Row Spacing	36"	8.9	10.3	12.2	16.8	17.9	20.5	23.4	27.7
	38"	8.5	9.8	11.5	15.9	16.9	19.4	22.2	26.2
	40"	8	9.3	11	15.1	16.1	18.5	21.1	24.9

TEMIK 15G		Grit							
		Double Sprocket: 12							
		Sprockets on insecticide meter box							
Driver		14	14	14	14	28	30	22	26
Driven		30	26	22	16	30	28	18	18
Row Spacing	36"	3.6	4.2	4.9	6.8	7.2	8.3	9.4	11.1
	38"	3.4	3.9	4.7	6.4	6.8	7.8	8.9	10.6
	40"	3.2	3.7	4.4	6.1	6.5	7.4	8.5	10

COUNTER 15G		Gypsum							
		Double Sprocket: 12							
		Sprockets on insecticide meter box							
Driver		14	14	14	14	28	30	22	26
Driven		30	26	22	16	30	28	18	18
Row Spacing	36"	5.4	6.2	7.4	10.1	10.8	12.4	14.1	16.7
	38"	5.1	5.9	7	9.6	10.2	11.7	13.4	15.8
	40"	4.9	5.6	6.6	9.1	9.7	11.2	12.7	15

THIMET 20G		Gypsum							
		Double Sprocket: 12							
		Sprockets on insecticide meter box							
Driver		14	14	14	14	28	30	22	26
Driven		30	26	22	16	30	28	18	18
Row Spacing	36"	5.5	6.3	7.5	10.2	10.9	12.5	14.3	16.9
	38"	5.2	6	7.1	9.7	10.4	11.9	13.6	16
	40"	4.9	5.7	6.7	9.2	9.8	11.3	12.9	15.2

MICROSEM MICROGRANULAR INSECTICIDE SYSTEM

Twin-Row

MICROSEM SYSTEM

The microsem system meters microgranular products such as insecticide and herbicide with precision. The system is ground driven and has a positive displacement. The output is set by a transmission that is unaffected by a change in planting speed. The microsem system is mounted to the toolbar frame with support brackets to reduce weight on the planter unit. The microsem system with auger is equipped with a telescoping outlet, and its output starts from a minimum of 2-3 lbs/acre.

Each microsem hopper has a 33 lb. capacity and can be used with a double outlet for two row units or with a single outlet for one row unit.

The drive sprocket is mounted on the upper hex shaft. The hoses direct the granular product directly between the disc openers via drop tubes, or behind the disc openers via a spreader tube.

TROUBLE SHOOTING

PROBLEM:

Variations between the outlets or metering boxes.

POSSIBLE CAUSE:

- There may be foreign material mixed with the product
- ATTENTION! there may be moisture in the product.
- The metering unit may have been assembled improperly.
- The outlet chute may be warped.
- The hose may be too long or bent, causing the hose to clog.

INSECTICIDE DROP TUBE

7085.SD Mounts on the right hand side of the unit, towards the front with a single bolt. It then curves down through a notch cut into the shield covering the front of the double disc opener. It deposits material into the seed trench in front of the seed tube. This tube is used on the set back unit on twin-row machines. The top of the tube curves to the left to accept the feeder hose coming down on the left hand side of the parallel linkage.



7085.SU Mounts on the right hand side of the unit, towards the front with a single bolt. It then curves down through a notch cut into the shield covering the front of the double disc opener. It deposits material into the seed trench in front of the seed tube. This tube is used on the set back unit on twin-row machines. The top of the tube extends straight up to accept the feeder hose coming through the middle of the parallel linkage.

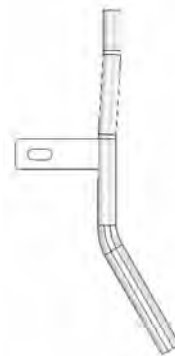

7085.DA Mounts on the right hand side of the unit, with the same bolts that attach the disc scraper. It deposits material down in the seed trench behind the seed tube. The top of the tube points straight up.



7085.GA Mounts on the left hand side of the unit, with the same bolts that attach the disc scraper. It deposits material down in the seed trench behind the seed tube. The top of the tube points straight up.

7085.SS



Mounts on the left hand side of the unit, with the same bolts that attach the disc scraper. It deposits material down in the seed trench behind the seed tube. The top of the tube curves towards the rear to accept the feeder hose from the Air Insecticide System.

MICROSEM MICROGRANULAR INSECTICIDE SYSTEM

Twin-Row

SETTING THE OUTPUT

The output is a function of the number of rotations of the spindle of the metering boxes, which is set primarily with the double sprocket (1) and the interchangeable sprockets (2). The chart provided will assist with the setting and also indicates the sprockets to be used for the principle commercial products. The furnished information is a recommendation only.

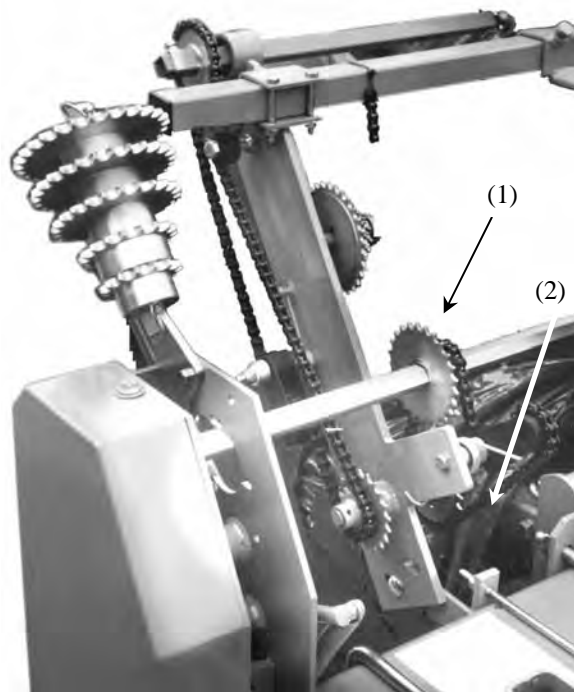

NOTE: Avoid moisture contamination. Moisture in the product will cause hardening and could cause chain breakage. To avoid this problem, empty hoppers and store in a dry place.

NOTE: This unit should be used only with microgranulars and not with powders or granulates. It is possible to meter large granulars provided the inside auger is changed for a special one.



WARNING Agricultural chemicals can be dangerous. Improper use can result in injury to persons, animals and soil. Handle with care and follow instructions of the chemical manufacturer.

HOW TO TEST FOR INSECTICIDE RATES

Measure out a distance of 328 feet (100m).

Set the sprocket combination to: A=12, B=30, C=12. (This ratio = 0.24 or the number of Microsem shaft rotations for 1 drive wheel rotation.)

Remove the hoses from a 2-outlet hopper, placing a bag or other container to catch the product. Put the product into the Microsem hopper. Engage the Microsem and drive forward the pre-measured distance. Weigh the amount of product caught in the container and convert to grams.

$$\begin{aligned} \text{Ounces} \times 31.103481 &= \text{grams} \\ \text{Inches} \times 2.54 &= \text{cm} \end{aligned}$$

Use the following formula:

$$\text{Output} = \frac{10 \times \text{quantity weighted (g)}}{\text{Inter-rows (cm)} \times 2}$$

Example:

Inter-rows = 60 cm (23.63")
Quantity weighed = 60 grams (1.929 oz)

If you require 8 kg/ha or 8 lb/acre, choose the ratio
 $\frac{8}{5} \times 0.24 = 0.384$
A=12, B=18, C=12

If you require 11 kg/ha or 11 lb/acre, choose the ratio
 $\frac{11}{5} \times 0.24 = 0.528$
A=12, B=22, C=20

$$\text{Output} = \frac{10 \times 60}{60 \times 2} = 5 \text{ kg/ha or } 5 \text{ lb/acre}$$

From the following chart, find the closest sprocket combination to achieve appropriate lbs/acre.

Note: Because of the large variety of insecticides and its density and irregularity of granulars, it is impossible to provide an exact chart. This is a close approximation only.

MICROSEM MICROGRANULAR INSECTICIDE SYSTEM

Twin-Row

Possible Sprocket Combinations

Ratios Obtained

A	B	C	
12	35	12	----- 0.21
12	32	12	----- 0.22
12	30	12	----- 0.24
12	25	12	----- 0.29
12	22	12	----- 0.33
12	20	12	----- 0.36
12	18	12	----- 0.40
12	16	12	----- 0.45
12	15	12	----- 0.48 or
12	25	20	----- 0.48
12	23	20	----- 0.51
12	22	20	----- 0.54
12	21	20	----- 0.57
12	12	12	----- 0.60
12	24	12	----- 0.63
12	18	21	----- 0.66
25	22	12	----- 0.68
12	10	12	----- 0.72
25	20	12	----- 0.75
12	15	20	----- 0.80
25	18	12	----- 0.83
25	16	12	----- 0.94
25	15	12	----- 1 or
12	12	20	----- 1
25	22	20	----- 1.13
12	10	20	----- 1.20
25	12	12	----- 1.25
25	18	20	----- 1.40
25	10	12	----- 1.50
25	15	20	----- 1.66
25	12	20	----- 2.08
25	10	20	----- 2.50

Less Product



Note: The bold sprocket numbers for the interchangeable B sprocket are standard.

The remaining sprockets for the interchangeable B sprocket are available on request. (13-14-16-23-26-35)



More Product

MICROSEM MICROGRANULAR INSECTICIDE SYSTEM

TWIN-ROW MICROSEM SETTING CHART - Drive sprockets to be used

These settings are theoretical and approximate. Actual output may vary. Other outputs can be obtained by using different sprocket arrangements of the Microsem drive, however travel speed variations will not affect the output.

- A = Double sprocket on hex shaft - driven 1**
- B = Interchangeable sprocket - driven 2**
- C = 12 or 20 tooth sprocket**

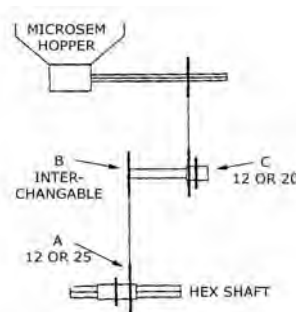

NOTE: For Planters with Sync-Row® seed timing system, the following rates need to be adjusted. Multiply these rates by 0.69.

		A / B / C	A / B / C	A / B / C	A / B / C	A / B / C	A / B / C
#'s per acre		4.8	5.4	6.2	7.2	8.1	9.0
THIMET	36"	12 / 25 / 12	12 / 22 / 12	12 / 18 / 12	12 / 16 / 12	12 / 23 / 20	12 / 21 / 20
20G	38"	12 / 22 / 12	12 / 20 / 12	12 / 16 / 12	12 / 25 / 20	12 / 22 / 20	12 / 12 / 12
	40"	12 / 20 / 12	12 / 18 / 12	12 / 15 / 12	12 / 23 / 20	12 / 21 / 20	25 / 24 / 12
#'s per acre		7.1	8.5	9.5	10.8	11.6	13.2
FURADAN	36"	12 / 30 / 12	12 / 25 / 12	12 / 22 / 12	12 / 20 / 12	12 / 18 / 12	12 / 16 / 12
15G	38"	12 / 27 / 12	12 / 22 / 12	12 / 20 / 12	12 / 18 / 12	12 / 16 / 12	12 / 23 / 20
	40"	12 / 25 / 12	12 / 20 / 12	12 / 18 / 12	12 / 16 / 12	12 / 23 / 20	12 / 22 / 20
#'s per acre		4.7	5.5	6.3	7.3	7.8	9.0
COUNTER 15G	36"	12 / 25 / 12	12 / 20 / 12	12 / 18 / 12	12 / 15 / 12	12 / 23 / 20	12 / 12 / 12
LORSBAN 15G	38"	12 / 22 / 12	12 / 18 / 12	12 / 15 / 12	12 / 23 / 20	12 / 22 / 20	25 / 24 / 12
	40"	12 / 20 / 12	12 / 15 / 12	12 / 23 / 20	12 / 22 / 20	12 / 12 / 12	12 / 18 / 20
#'s per acre		6.5	7.8	8.9	9.7	10.8	
TEMIK	36"	12 / 30 / 12	12 / 25 / 12	12 / 22 / 12	12 / 20 / 12	12 / 18 / 12	
15G	38"	12 / 27 / 12	12 / 22 / 12	12 / 20 / 12	12 / 18 / 12	12 / 16 / 12	
GYPSUM	40"	12 / 25 / 12	12 / 20 / 12	12 / 18 / 12	12 / 16 / 12	12 / 15 / 12	
#'s per acre		5.2	6.3	7.1	8.6	10.3	
AMEBIN	36"	12 / 30 / 12	12 / 25 / 12	12 / 22 / 12	12 / 18 / 12	12 / 15 / 12	
	38"	12 / 25 / 12	12 / 22 / 12	12 / 18 / 12	12 / 16 / 12	12 / 23 / 20	
	40"	12 / 22 / 12	12 / 18 / 12	12 / 16 / 12	12 / 15 / 12	12 / 22 / 20	

MICROSEM MICROGRANULAR INSECTICIDE SYSTEM

TWIN-ROW MICROSEM SETTING CHART - Drive sprockets to be used

These settings are theoretical and approximate. Actual output may vary. Other outputs can be obtained by using different sprocket arrangements of the Microsem drive, however travel speed variations will not affect the output.

NOTE: For Planters with Sync-Row® seed timing system, the following rates need to be adjusted. Multiply these rates by 0.69.

	A / B / C	A / B / C	A / B / C	A / B / C	A / B / C	A / B / C
#'s per acre	4.4	5.3	5.7	6.0	6.7	7.3
TEMIK 15G 36"	12 / 18 / 12	12 / 15 / 12	12 / 23 / 12	12 / 22 / 20	12 / 12 / 12	12 / 18 / 20
CORNCOB 38"	12 / 15 / 12	12 / 23 / 20	12 / 22 / 20	12 / 12 / 12	12 / 24 / 12	25 / 22 / 12
GRIT 40"	12 / 23 / 20	12 / 22 / 20	12 / 12 / 12	12 / 24 / 12	12 / 18 / 20	12 / 10 / 12
#'s per acre	7.6	8.3				
	25 / 22 / 12	25 / 20 / 12				
	12 / 10 / 12	12 / 15 / 20				
	25 / 20 / 12	25 / 18 / 12				

#'s per acre	4.0	4.5	5.4	6.1	6.7	7.4
ZENECA FORCE 3G 36"	12 / 20 / 12	12 / 18 / 12	12 / 15 / 12	12 / 12 / 12	12 / 12 / 12	12 / 18 / 20
38"	12 / 18 / 12	12 / 15 / 12	12 / 23 / 20	12 / 12 / 12	25 / 24 / 12	25 / 22 / 12
40"	12 / 16 / 12	12 / 23 / 20	12 / 22 / 20	24 / 24 / 12	12 / 18 / 20	25 / 20 / 12
#'s per acre	8.4					
	25 / 20 / 12					
	12 / 15 / 20					
	12 / 18 / 12					

#'s per acre	4.0	4.4	4.9	5.8	6.6	7.4
RIDOMIL 36"	12 / 22 / 12	12 / 20 / 12	12 / 18 / 12	12 / 15 / 12	12 / 22 / 20	12 / 12 / 12
GOLD GR 38"	12 / 20 / 12	12 / 18 / 12	12 / 15 / 12	12 / 23 / 20	12 / 12 / 12	12 / 18 / 20
PC11G 40"	12 / 18 / 12	12 / 15 / 12	12 / 23 / 20	12 / 22 / 20	12 / 18 / 20	25 / 22 / 12
#'s per acre	8.1					
	12 / 18 / 20					
	25 / 22 / 12					
	25 / 20 / 12					

#'s per acre	5.1	5.8	6.4	7.1	8.5	9.5
GOLD PC 36"	12 / 25 / 12	12 / 22 / 12	12 / 20 / 12	12 / 18 / 12	12 / 15 / 12	12 / 22 / 20
38"	12 / 22 / 12	12 / 20 / 12	12 / 18 / 12	12 / 15 / 12	12 / 22 / 20	12 / 12 / 12
40"	12 / 20 / 12	12 / 18 / 12	12 / 15 / 12	12 / 22 / 20	12 / 12 / 12	12 / 18 / 20

MICROSEM INSECTICIDE ASSEMBLY

Microsem Assembly

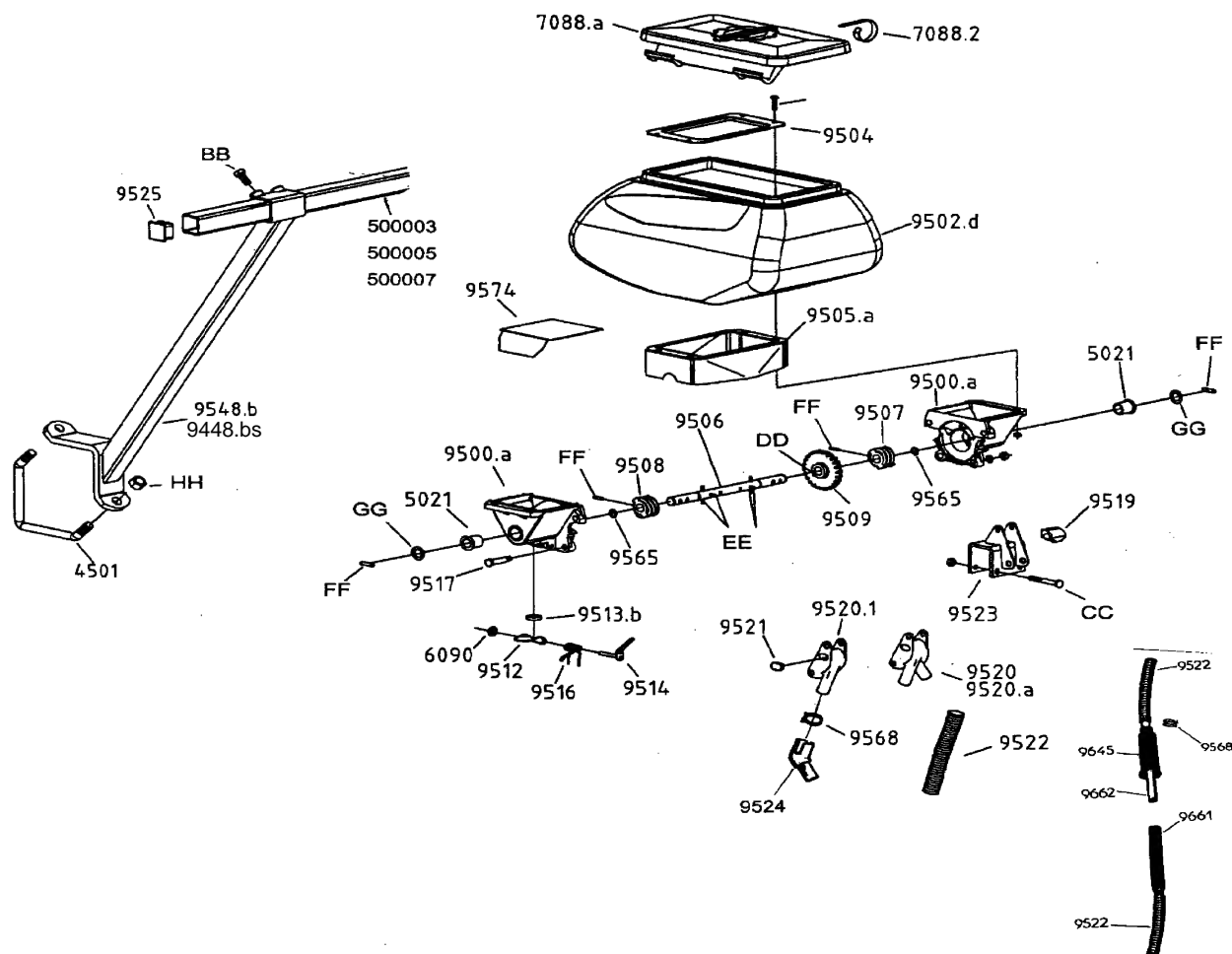

PART No. DESCRIPTION

4501	V-bolt, 16mm
5021	Self lubricated bushing
6090	Snapping, 6mm
7085.da	Drop tube, right hand
7085.ga	Drop tube, left hand
7088.a	Lid, hopper, with clip (7088.2)
7088.2	Clip, for hopper lid
9500.a	Housing(half), metering unit (replaces old 9500 & 9501 left & right sides)
9502.d	Plastic hopper only, 25 liter, -'03
9504	Steel base (hopper to meter)
9505.a	Rubber skirt
9506	4x35 roll pins)
9507	Worm gear, lft(reqrs 6x25 roll pin)
9508	Worm gear, rht(reqrs 6x25 roll pin)
9509	4x25 roll pin)
9512	Trap door (to clean out meter unit)
9513.a	Seal for trap door
9514	Lever for trap door
9516	Spring for trap door
9517	Bolt (fastens housings together)
9519	Rubber plug
9520	Two outlet chute (towards the front)
9520.a	Two outlet chute (towards the rear)

PART No. DESCRIPTION

9520.1	Single outlet
9521	Rubber plug for side of chute
9522	Hose (specify length)
9523	Clamp/mounting bracket
9524	Elbow for single outlet
9525	End cap for bar
9548.b	Support bar(for mounting to a 5x5 bar)
9548.bs	Support bar(for mounting to a 7x7 bar)
9565	Rubber O-ring
9568	Hose clamp (for 9522)
9574	Plate for hopper (to convert to single outlet)
9645	Protective Sleeve
9661	Female half of sliding drop tube assy
9662	Male half of sliding drop tube assy
500003	Carrier bar, 8' 2" long(1-1/2" square)
500005	Carrier bar, 11' 6" long(1-1/2" square)
500007	Carrier bar, 14' 9" long(1-1/2" square)
AA	10530096 - Phillips head bolt, 6 x 25
BB	HM-61225 - Hex bolt, 12 x 25
CC	HM-2860 - Hex bolt, 8 x 60
DD	10172041 - Roll pin, 4 x 25
EE	10172043 - Roll pin, 4 x 35
FF	10172090 - Roll pin, 6 x 25
GG	10622024 - Washer, 16 x 26 x 1
HH	NM-51605 - 16mm nylon locknut

MICROSEM TRANSMISSION

Twin-Row

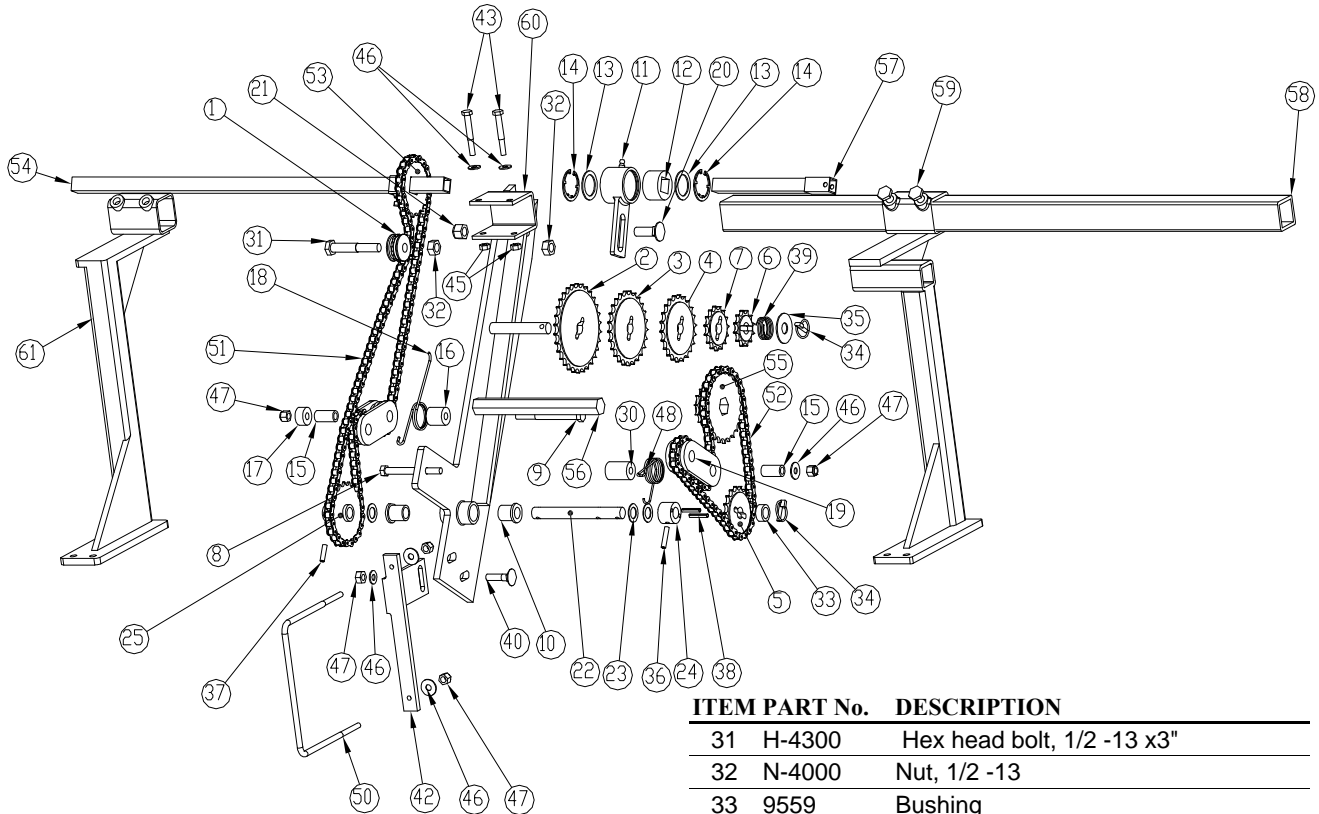

ITEM PART No.	DESCRIPTION
1	9562 Chain roller
2	9554.21 Interchangeable sprocket, 30T
3	9554.16 Interchangeable sprocket, 25T
4	9554.13 Interchangeable sprocket, 22T
5	9554.9 Interchangeable sprocket, 18T
6	9554.3 Interchangeable sprocket, 12T
7	9554.6 Interchangeable sprocket, 15T
8	H-3320 Hex head bolt, 3/8" -16 x 3 1/2"
9	H-3410 Hex head bolt, 3/8" -16 x 4"
10	5021 Self lubricated bushing
11	E2002 Housing to hold nylon bushing
12	9280 Nylon support bushing
13	10624014 Flat washer, 31x 41x 1
14	4329.A Snapping 44mm
15	KD1026 Sleeve, 1 3/16" long
16	E2004 Spacer, 1" long
17	E2005 Spacer, .6" long
18	7157 Spring
19	KD11962 Chain idler, plastic
20	CB-4411 Carriage head bolt, 1/2 -13 x 1 1/2"
21	N-2300 Rev lock nut, 1/2 -13
22	9612 Intermediate shaft
23	10622024 Flat washer, 16.5 x26 x1
24	9552 Spacer/driver for sprocket
25	9654 Double intermediate sprocket, 12- 20T
30	E2003 Spacer, 1.4" long

ITEM PART No.	DESCRIPTION
31	H-4300 Hex head bolt, 1/2 -13 x3"
32	N-4000 Nut, 1/2 -13
33	9559 Bushing
34	9557 Lynch pin
35	W-5410 Flat washer, 5/8 SAE
36	10172091 Roll pin, 6 x 30
37	10172090 Roll pin, 6 x 25
38	10170065 Roll pin, 5 x 30
39	9158 Compression spring
40	CB-2221 Carriage head bolt, 3/8 -16 x 1 1/2"
42	E2007 Mounting strap to 7 x 7 toolbar
43	HM-2865 Hex head bolt, 8 x 60mm
45	NM-1801 Nut, 8mm
46	W-2210 Flat washer, 3/8, USS
47	N-2101 Nylon locknut, 3/8 -16
48	7150 Spring
50	4647.S U Bolt, 7 x 7, 3/8 -16
51	9553.E Upper drive chain, 5R, 99 links for 12T driver sprocket, 103 links for 20T
52	9553.F Lower drive chain, 5R, 60 links for 25T driver sprocket, 54 links for 12T
53	9606.A Sprocket, square drive, 20T
54	9651.085 Female drive conductor tube, 33 1/2"
55	9555.A Double drive sprocket, hex bore, 12- 25T
56	4520 7/8" Hex shaft
57	9650.085 Male drive connector tube, 33 1/2"
58	9549.125 Carrier bar, 1 1/2" sq., specify length
59	E1011 Support bracket with offset
60	E2001 Transmission main frame
61	E1010 Support bracket

DRY FERTILIZER

Pull-Type Planters

DOUBLE DISC FERTILIZER OPENER

Position the double disc fertilizer during assembly to place the fertilizer no closer than 2" to either side of the row. If planter frame is level and at proper planting height, fertilizer depth will be approximately 4". Soil conditions can affect depth slightly.

The down pressure spring is factory preset at 250 lbs down pressure but may be adjusted for various soil conditions. To adjust spring tension, loosen the jam nut with a 15/16" wrench and use a 1" wrench to turn the adjustment bolt clockwise to increase tension or counter-clockwise to decrease tension. Securely tighten the jam nut upon completion of tension adjustment. Do not attempt to set opener depth with spring pressure. The opener is designed to operate against depth stop and spring up when encountering a foreign object or hard ground.

CAUTION: Do not operate the double disc openers at full down pressure tension when planting in rocky ground. Chipping of the blades will occur.

Maintain a gap of 1/32" to 1/16" between the closest points of the opener blades. Adjust the blades by moving the inside spacer washers to the outer side of the blade. After making this adjustment, check to be sure bearing assembly rivets are not hitting shank. The outer scrapers on each blade may also be adjusted to make up for wear that may occur. Adjust the scraper to allow only slight contact with the blade.

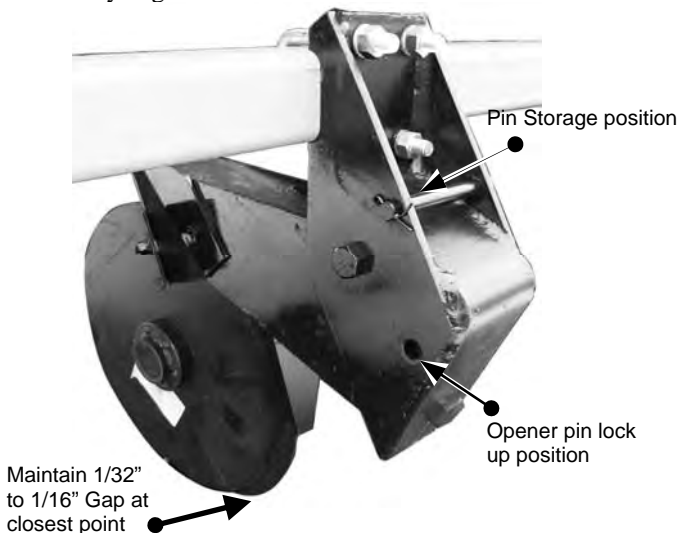

Lock the opener assembly in a raised position when the fertilizer attachment is not in use or during storage. To lock the opener, first raise the planter and place blocks under the openers. Then lower the planter until the hole in the pivot section aligns with the hole in the mounting bracket. Remove the lockup pin from the

storage position in the mounting bracket an install it through the lockup hole and secure with cotter pins.

DANGER: Always install all cylinder lockup brackets before working under the unit.

DRY FERTILIZER ADJUSTMENTS

The rate of fertilizer application is determined by

- ① the auger position in the hopper and
- ② the drive/ driven sprocket combination on the fertilizer drive.

① Adjusting the augers

Remove 1/4" stainless steel cap screws holding augers in place on shaft and reposition augers to change delivery rate. Do not use a high rate position at too low a rate setting; this will cause uneven delivery of fertilizer. Check the rate chart.

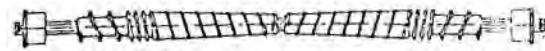

② Adjusting the sprockets

A transmission for the fertilizer is located on the right side of the planter directly ahead of the row unit transmission. This transmission is designed to allow simple, rapid changes in sprockets to obtain the desired fertilizer application rates. By removing the pins on the hexagonal shafts, sprockets can be interchanged with those on the sprocket storage rod bolted to the transmission plate.



DRY FERTILIZER

Pull-Type Planters

Chain tension is controlled by a spring loaded idler. This idler is adjusted with a ratchet arm located to the inside of the transmission. This arm has a release position to remove spring tension for replacing sprockets. The amount of spring tension on the chain can be controlled by the ratchet arm.

Use the fertilizer application chart to select the correct sprocket combinations.

IMPORTANT: After each sprocket combination adjustment, make a field check to be sure you are applying fertilizer at the desired rate.

APPLICATION RATES

The dry fertilizer attachment meters granules by volume rather than weight. For this reason, and given the variances in brands and fertilizer analysis, the weight metered during actual application may vary considerably. Use the Application Rates chart for *reference only*. It is suggested that a container be used to catch and measure application to obtain a closer estimate.

 **WARNING:** Agricultural chemicals can be dangerous. Improper use can result in injury to persons, animals and soil. Handle with care and follow instructions of chemical manufacturer.

The following rates were calculated with a bulk density of 65 lbs/cubic foot. This chart is for planters that are equipped with contact drive. In lbs/ acre

IMPORTANT: Fertilizer application rates can vary from the weights calculated in this chart due to different brands, temperature, humidity, etc. These settings are theoretical and approximate. Actual output may vary. To prevent application miscalculations, make a field test

CLEANING

Since most fertilizers absorb moisture, it is important that you keep fertilizer dry during use and storage. In addition to waste, deposits of fertilizer left in the hopper can cause metal corrosion. Hoppers should be emptied at the end of each day's use.

At the end of the planting season, or when fertilizer attachment is not going to be used for a period of time, the hoppers should be disassembled, cleaned and metal surfaces coated with a rust preventative.

 **IMPORTANT:** If fertilizer is placed too close to the seed, it may cause germination or seedling damage especially if used in amounts in excess of fertilizer manufacturer's recommendations. Check

with your fertilizer dealer or manufacturer for the correct amount and placement.

The dry fertilizer hoppers are designed to tip forward for dumping and ease of cleaning. To dump hoppers, first disconnect the drive shaft from the transmission or adjacent hopper. **LOOSEN HOES CLAMPS AND REMOVE HOSES FROM EACH HOPPER.**

1. Remove the two rear ½" x 1 ¼" cap screws from between hopper support and opener mounting bar. Loosen the two front ½" x 1 ¼" cap screws. Rotate hopper lids to the backside of hopper and carefully tip hopper forward. After dumping contents, flush all loose fertilizer from the hopper and hoses. To disassemble auger assemblies, remove ¼" cotter pin and bearing from one end of the shaft. Pull auger assembly from opposite end of hopper. Remove stainless steel cap screws from auger shaft and remove all auger components for cleaning. Coat all parts with rust preventative before reassembly. Reinstall auger halves in proper low rate or high rate position.

2. To reassemble, slide auger assembly through the outlet housing back into the hopper. Secure in place by reinstalling the bearing and cotter pin.

3. auger installation by rotating shaft in the direction of planter travel to see that the spirals on the auger move toward the ends of the hopper. If not, remove auger assembly, turn 180° and reinstall.

4. Be certain that the augers turn freely. If not, loosen the 5/16" carriage bolts in the outlet housings, rotate the auger several times and retighten the 5/16" carriage bolts.

5. This should allow the housings to realign themselves with the auger.

6. Install auger baffles over the augers and secure in place with two hairpin clips in each hopper. Do not operate fertilizer attachment without auger baffles in place.

IMPORTANT: Frequent lubrication of auger bearings is critical to ensure that the augers will turn freely. Check lubrication section for frequency.

7. **NOTE:** Be sure to install the auger so the flighting on the augers move material to the outer openings in the hopper when the augers are rotated in the direction they will turn when the planter is in operation.

DRY FERTILIZER

Pull-Type Planters

APPLICATION RATES

The dry fertilizer attachment meters granules by volume rather than weight. For this reason, and given the variances in brands and fertilizer analysis, the weight metered during actual application may vary considerably. Use the Application Rates chart for *reference only*. It is suggested that a container be used to catch and measure application to obtain a closer estimate.

WARNING: Agricultural chemicals can be dangerous. Improper use can result in injury to persons, animals and soil. Handle with care and follow instructions of chemical manufacturer.

The following rates were calculated with a bulk density of 65 lbs/cubic foot. This chart is for planters that are equipped with contact drive. In lbs/ acre

IMPORTANT: Fertilizer application rates can vary from the weights calculated in this chart due to different brands, temperature, humidity, etc. These settings are theoretical and approximate. Actual output may vary. To prevent application miscalculations, make a field test

HOW TO TEST FOR FERTILIZER RATES

To determine lbs/acre for your desired fertilizer at 30" Row spacing, follow these steps.

1. Remove one spout from one of the fertilizer hoppers and attach a container under the opening.
2. Engage the fertilizer attachment and drive forward 174 feet.
3. Weigh the amount of fertilizer caught in the container (in ounces), and multiply that number by 100.
4. The result will be the pounds of fertilizer delivered per acre when planting in 30" rows. To convert this delivery rate for wider rows, use the following conversion factors.
 36" Row spacing, multiply the ounces by 0.83
 38" Row spacing, multiply the ounces by 0.79
 metered during actual application may vary considerably. Use the Application Rates chart for *reference only*. It is suggested that a container be used to catch and measure application to obtain a closer estimate.

APPLICATION RATES

A /	B	LOW RATE SETTINGS			HIGH RATE SETTINGS		
		30" Rows	36" Rows	38" Rows	30" Rows	36" Rows	38" Rows
15 /	35	32	26	25	94	78	74
15 /	33	36	30	28	109	91	86
15 /	30	39	33	31	120	100	95
19 /	33	45	37	36	135	114	107
19 /	30	50	42	39	153	126	120
15 /	19	58	48	46	174	144	136
30 /	35	61	51	48	188	156	148
30 /	33	67	55	52	200	166	157
33 /	35	69	58	55	206	172	163
35 /	33	76	63	61	214	193	183
33 /	30	81	67	64	241	200	190
19 /	15	93	77	73	278	230	219
30 /	19	116	96	91	347	288	274
33 /	19	127	105	100	382	317	301
35 /	19	133	111	106	402	335	318
30 /	15	146	121	115	440	365	347
33 /	15	161	134	127	482	400	380
35 /	15	168	141	133	510	424	403

↓
DIRECTION OF ROTATION

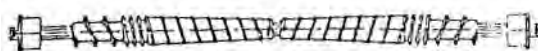

HIGH RATE POSITION



LOW RATE POSITION

DRY FERTILIZER

Pull-Type Planters

ASSEMBLY

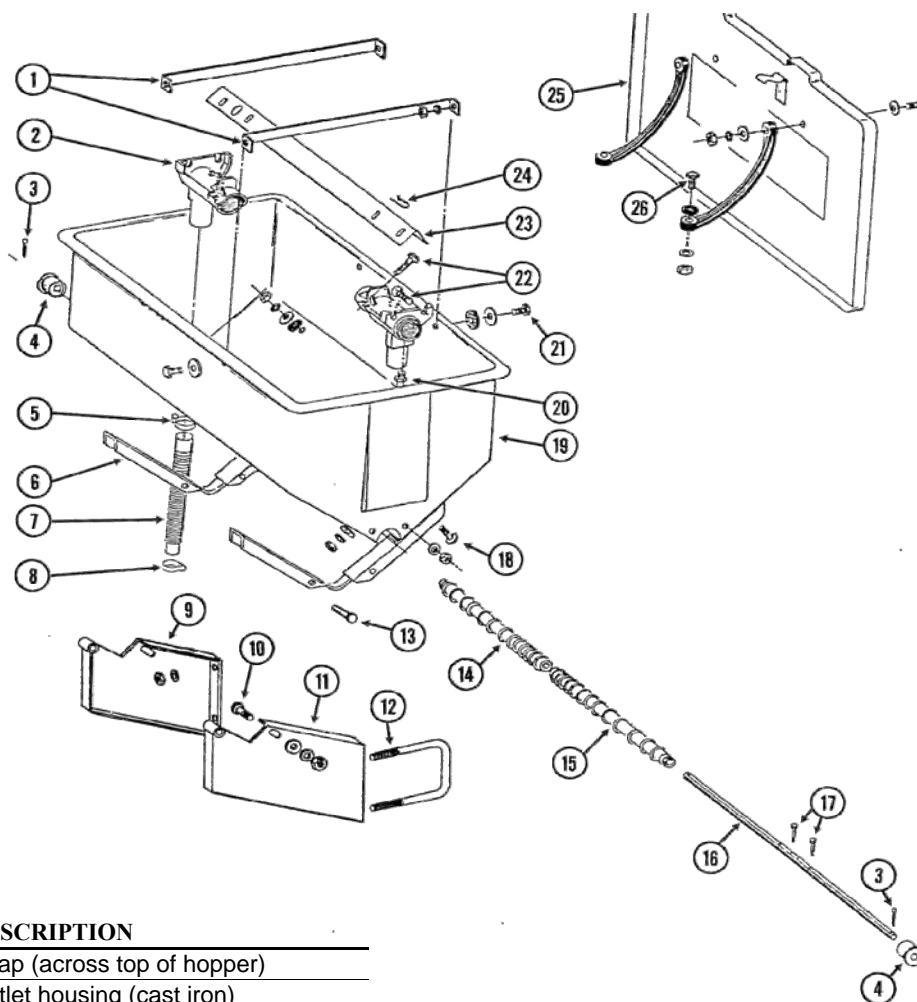

ITEMPART No.	DESCRIPTION
1	KD1209 Strap (across top of hopper)
2	KD1200 Outlet housing (cast iron)
3	K10460 Cotter pin, 1/4" x 2"
4	KB0200 Auger bearing
5	K10676 Clamp, No. 36
6	KA5652 Saddle (to support hopper)
7	KD3790 Rubber hose, standard(9" to 16") KD1925 Rubber hose, extra long(14" to 24")
8	K10672 Clamp, No. 28
9	KA2534 Hopper mounting bracket, RH
10	H-4110 Bolt, 1/2" x 1-1/4"
11	KA2533 Hopper mounting bracket, LH
12	4502.S U-bolt, 7" x 7" x 5/8"
13	K10561 Pin, 1/2" x 3" K10451 Cotter pin, 1/8" x 1"
14	KB0198 Auger, RH (as standing behind planter)
15	KB0199 Auger, LH (as standing behind planter)
16	KD7848 Shaft for auger
17	K10587 Bolt, 1/4" x 2", stainless steel K10588 Nut, 1/4"-20, stainless steel
18	CB-1114 Carriage bolt, 5/16" x 1-1/4" K10201 Special washer KD1213 Rubber washer W-1610 Lock washer, 5/16" N-1001 Nut, 5/16"-18
19	KD1379 Hopper (bare shell)

ITEMPART No.	DESCRIPTION
20	K10641 Grease fitting, 1/8" NPT
21	K10171 Bolt, 5/16" x 1-1/4" K10201 Special washer KD1213 Rubber washer W-1610 Lock washer, 5/16" N-1001 Nut, 5/16"-18
22	CB-1110 Carriage bolt, 5/16" x 1", grade 2
23	KD1207 Baffle (galvanized steel)
24	K10670 Hair pin clip, No. 3
25	KA0898 Lid assembly complete(clips, rubber straps, and hardware) KD1380 Front clip KD1210 Rubber strap
26	H-2120 Bolt, 5/16" x 1-1/2" W-1210 Flat washer, 5/16" W-1610 Lock washer, 5/16" N-1001 Nut, 5/16"-18
	KA5666 Hopper assembly(items 2,6,18, 19,22, & 24)
	KA5667 Auger, baffle & straps(items 1, 3,4,14,15,16,17, & 23)
	K6796X Mounting bracket kit complete (items 9,10,11,12, & 13)

DRY FERTILIZER

Pull-Type Planters

ASSEMBLY

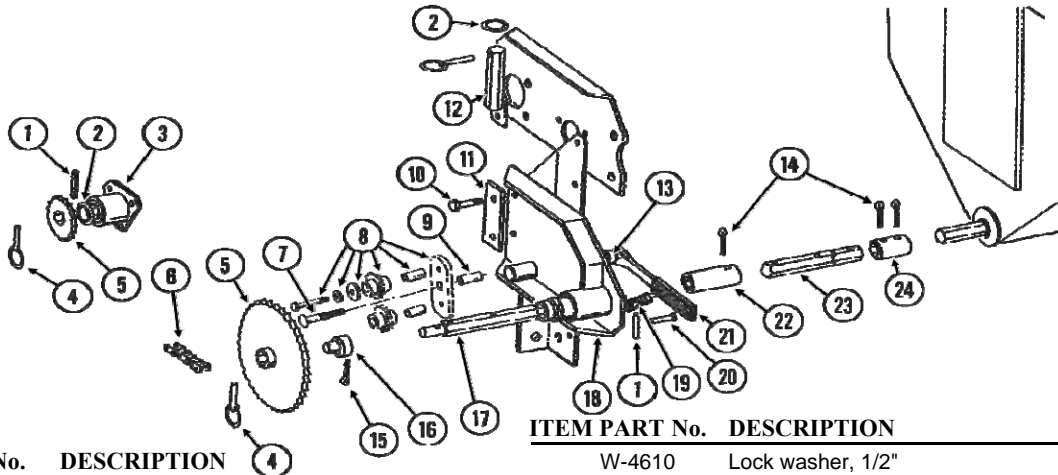

ITEM PART No.	DESCRIPTION	ITEM PART No.	DESCRIPTION
1	K10602 Roll pin, 1/4" x 1-1/2"	11	W-4610 Lock washer, 1/2"
2	K10233 Machine bushing, 1"ID x 1-1/2"OD, 1/8" thick	12	N-4001 Nut, 1/2"
3	KA5223 Spacer w/bearing KA5116 Bearing, 7/8" hex bore, cylindrical	13	KD8246 Overlay
4	KD2558 Lynch pin, 1/4"	14	KA5229 Sprocket storage rod
5	KA5105 Sprocket, 15 tooth, #40 KA5107 Sprocket, 19 tooth, #40 KA5114 Sprocket, 30 tooth, #40 KA5115 Sprocket, 33 tooth, #40 KA6337 Sprocket, 35 tooth, #40	15	KD10161 Spacer, 3/8"
6	K3310-98 Chain, #40, 98 links(w/conn. link)	16	K10460 Cotter pin, 1/4" x 2"
7	K10419 Carriage bolt, 1/2" x 4-1/2"	17	K10462 Cotter pin, 3/16" x 2"
8	K10111 Lock nut, 1/2"	18	KD7127 Shear coupler
9	KA7336 Idler w/bolt on sprockets KD7426 Plastic sprocket KD1026 Spacer, 1-3/16" W-2410 Washer, 3/8" W-2610 Lock washer, 3/8" H-3130 Bolt, 3/8" x 1-3/4"	19	KD7870 Shaft, 7"
10	KD31380-17 Sleeve, 2-5/16" wide	20	KA5678 Plate w/bearings and grease fitting KA5116 Bearing, 7/8" hex bore, cylindrical KA5624 Bearing, 7/8" hex bore, extended sleeve w/cross drilled hole
		21	K10640 Grease fitting, 1/4"-28
		22	KD5857 Spring
		23	K10408 Clevis pin, 5/16" x 3/4"
		24	K10409 Retaining ring, 5/16"
			KA4235 Ratchet wrench w/protective covering K10445 Protective covering(on handle)
			KD7867 Coupler, 3"
			KD7871 Hex shaft, 6"
			KD5886 Coupler, 1-3/4"

MOUNTING BAR

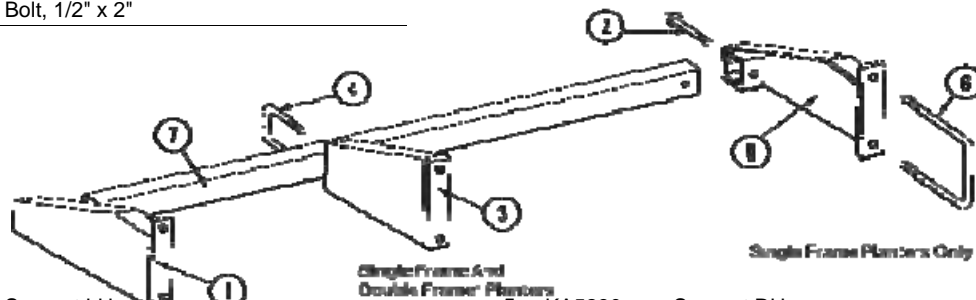

1	KA5231 Support LH	5	KA5230 Support RH
2	H-4401 Bolt, 1/2" -13x 4" N-4001 Hex nut 1/2" -13 W-4610 Lock washer, 1/2"	6	KD1114 U-Bolt 7" x 7"x 5/8"- 11 N-5001 Hex nut 5/8" -11 W-5610 Lock washer, 5/8"
3	KA5236 Support RH 8-row KA5237 Support LH 8-row	7	KD1685-12 Bar, 205 6-row 36 KD1685-13 Bar, 165 6-row 30 KD1685-14 Bar, 105 4-row 30 KD1685-15 Bar, 129 4-row 36/38 KD1685-16 Bar, 225 8-row 30
4	KD1138 U-Bolt 2 1/2" x 2 1/2"x 1/2"- 13 N-4001 Hex nut 1/2" -13 W-4610 Lock washer, 1/2"		

DRY FERTILIZER

Pull-Type Planters

DOUBLE DISC FERTILIZER OPENER

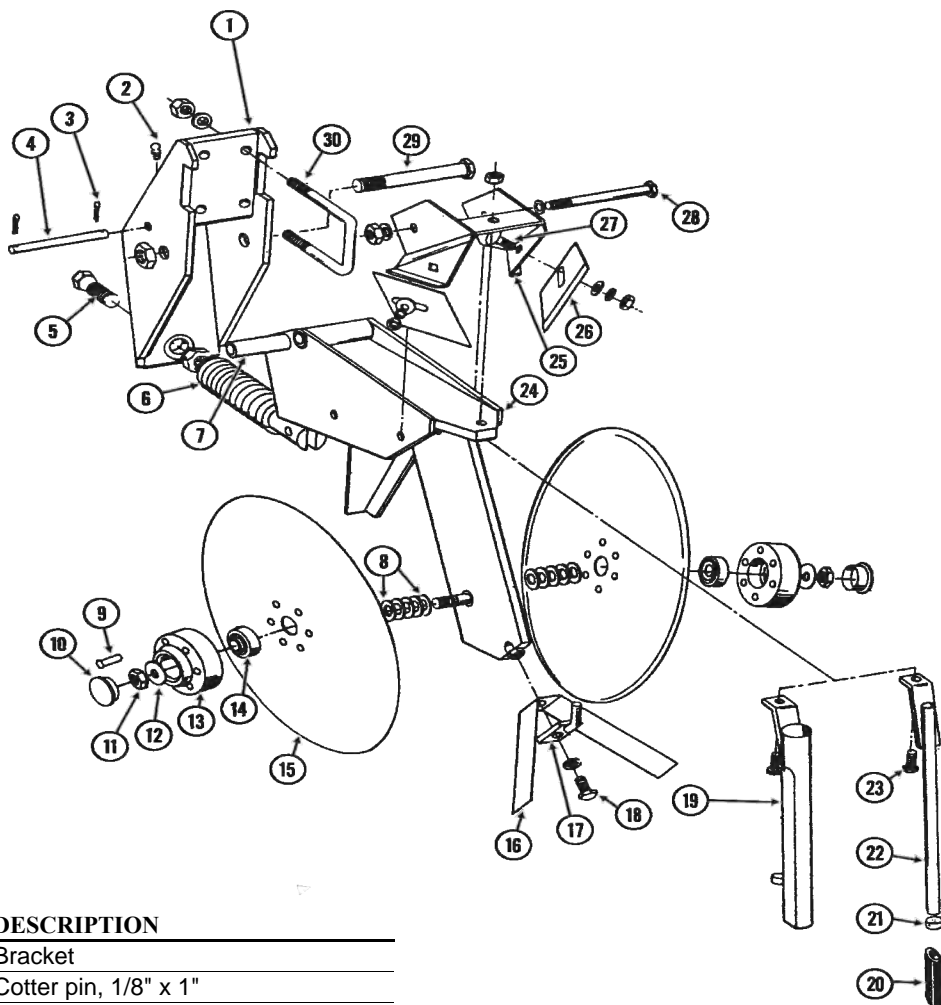

ITEMPART No. DESCRIPTION

1	KA0785	Bracket
2	K10451	Cotter pin, 1/8" x 1"
3	KD1657	Lockup pin
4	KD1657	
5	KD0962	Hex head adj. bolt, 5/8" -18
5	K10499	Jam Nut, 5/8" -18
6	KA0328	Spring
7	KD0487	Bushing
8	K10213	Machine bushing, 11/16"
9	K10542	Rivet, 1/4" x 1 5/16"
10	KD1132	Cap
11	K10503	Jam Nut, 5/8" -11 RH
11	K10504	Jam Nut, 5/8" -11 LH
12	K10204	Machine bushing, 21/32"
13	KB0134	Hub
14	KA2014	Bearing
15	KD1030	Blade
16	KD2589	Inner Scraper
17	KA0312	Mount
18	K10019	Hex head cap screw, 5/16" - 18 x 1"
18	K10232	Lock washer, 5/16"
19	KA1369	Drop Tube
20	KD1797	Extension
21	K10681	Clamp, No. 6
22	KA0318	Drop Tube, Liquid Fertilizer

ITEMPART No. DESCRIPTION

23	K10133	Hex head cap screw, 5/16" -18 x 1 1/2
23	K10109	Lock nut 5/16" -18
24	KA0308	Shank
25	KA0810	Scraper Mount
26	KD1673	Scraper
27	K10305	Carriage bolt, 3/8" -16x1"
27	K10210	Washer, 3/8" USS
27	K10229	Lock washer, 3/8"
27	K10101	Hex nut 3/8" -16
28	K10045	Hex head cap screw, 1/2" -13x 4 1/2"
28	K10111	Lock nut 1/2" -13
29	K10046	Hex head cap screw, 5/8" - 11x5"
29	K10107	Lock nut 5/8" -11
30	KD1339	U-Bolt 2 1/2" x 2 1/2"x 1/2"- 13
30	K10102	Hex nut 1/2" -13
30	K10228	Lock washer, 1/2"

LIQUID FERTILIZER

Pull-Type Planters

PUMP MOUNTING AND HOSE ARRANGEMENT

The squeeze pump is shipped with the discharge manifold in the **rearward or non-operating** position. Before operating or mounting the pump, position the discharge manifold in the forward or operating position and secure by tightening the wing nuts.

The pump should always be mounted even with or lower than the fertilizer tank for accurate metering. The rate of liquid fertilizer application is determined by the combination of sprockets on the squeeze pump and the drive shafts (see chart). When changing the sprocket combinations, check that the sprockets are in alignment, that the sprocket retaining collars are tight and that the chain tension is restored.

The shut-off valves should be closed to shut off the flow when the pump is not in use, either overnight, or for an extended amount of time. Also close the valves when servicing either the pump or the hoses.

To prolong the life of the hoses, the discharge manifold must be repositioned to the rearward position when not in use to prevent hose distortion.

The discharge pump must be in the forward position when the pump is in operation. To reposition the manifold, loosen the wing nuts and slide the manifold forward and sideways or rearward as required and retighten the nuts.

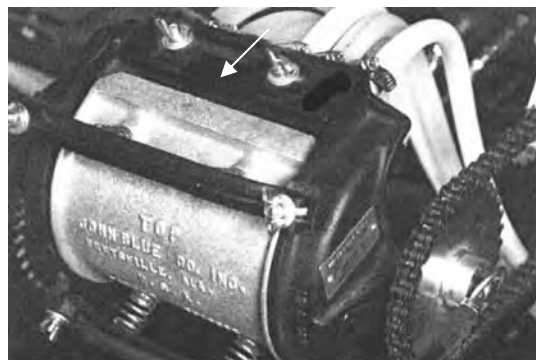

DISCHARGE MANIFOLD REARWARD

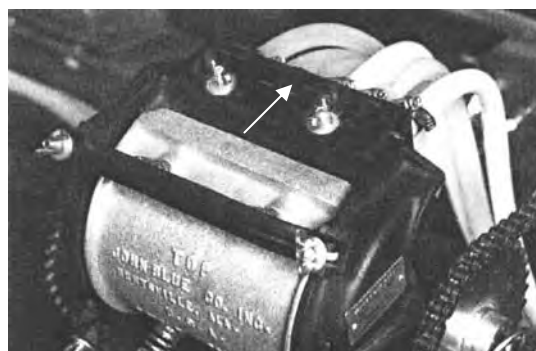

DISCHARGE MANIFOLD FORWARD



WARNING

Agricultural chemicals can be dangerous. Improper use can result in injury to persons, animals, and soil. Handle with care and follow instructions of the chemical manufacturer.

IMPORTANT

Do not place fertilizer too close to seed, it may cause germination or seedling damage. This is even more likely to occur if used in amounts in excess of the fertilizer manufacturer's recommendations. Check with your fertilizer dealer or manufacturer for the correct amount and placement of fertilizer.

LIQUID FERTILIZER

Pull-Type Planters

SQUEEZE PUMP APPLICATION RATES

Drive	Driven	30"	36"	38"
Gallons per Acre				
15	*62	6.9	5.8	5.5
19	*62	8.8	7.3	6.9
15	46	9.3	7.8	7.4
19	46	11.8	9.8	9.3
15	34	12.6	10.5	9.9
15	32	13.4	11.2	10.6
32	*62	14.7	12.3	11.6
19	34	16.	13.3	12.6
19	32	17.	14.1	13.4
32	46	19.9	16.6	15.7
34	46	21.1	17.6	16.7
Drive	Driven	30"	36"	38"
Gallons per Acre				
46	*62	21.2	17.7	16.7
15	19	22.5	18.8	17.8
32	34	26.9	22.4	21.2
34	32	30.3	25.3	24
19	15	36.2	30.1	28.6
46	34	38.6	32.2	30.5
46	32	41.	34.2	32.4
32	19	48.1	40.1	38.
34	19	51.1	42.6	40.3
*62	34	52.1	43.4	41.1

Above chart is for planters equipped with contact drive. See "Tire Pressure" for recommended tire pressures.

This chart was calculated based on a solution weighing ten pounds per gallon.

NOTE: Fertilizer application rates can vary from the above chart. To prevent application miscalculations, make field checks to be sure you are applying fertilizer at the desired rate. Follow the instructions on the following page to make a **FIELD CHECK**.

OPTIONAL PISTON PUMP

If the machine is equipped with the piston pump option, the rate of liquid fertilizer application is determined by the piston pump settings.

To adjust delivery rate, loosen the 3/8" lock nut that secured the arm with the pointer and rotate the scale flange until the pointer is over the desired scale setting. The adjustment wrench will facilitate rotation of the scale flange. Tighten the 3/8" lock nut being careful not to over tighten.



CLEANING

The tanks and all hoses are made of sturdy plastic and rubber to resist corrosion. However, the tanks, hoses and metering pump should be thoroughly cleaned with water at the end of the planting season or prior to an extended period of non-use. Do not allow fertilizer to crystallize due to cold temperature or evaporation.

On machines equipped with the piston pump, the strainer located between the piston pump and ball valve should be taken apart and cleaned daily. Remove the end cap to clean the screen

PISTON PUMP STORAGE

KEEP AIR OUT OF THE PUMP! This is the only way to prevent corrosion. Even for short periods of storage, the entrance of air into the pump will cause **RAPID AND SEVERE CORROSION**.

Overnight Storage

Suspension Fertilizer must be flushed from the pump for ANY storage period.

Winter Storage

1. Flush pump thoroughly with 5 to 10 gallons of fresh water and circulate until all corrosive salts are dissolved in the pump.
2. With the pump set on 10, draw in a mixture of half diesel fuel and half 10 weight oil until the discharge is clean. Then plug inlet and outlet

LIQUID FERTILIZER

Pull-Type Planters

PISTON PUMP APPLICATION RATES

Pump Setting	1	2	3	4	5	6	7	8	9	10
4-row 30"	8.3	16.5	24.8	32.6	41.3	49.5	57.8	66.0	74.3	83.5
4-row 36"	6.9	13.7	20.6	27.5	34.4	41.3	48.2	55.0	61.9	68.8
4-row 38"	6.5	13.0	19.5	26.0	32.6	39.1	45.6	52.1	58.7	65.2
6-row 30"	5.5	11.0	16.5	22.0	27.5	33.0	38.5	44.0	49.5	55.0
6-row 36"	4.6	9.2	13.7	18.3	22.9	27.5	32.1	36.7	41.3	45.9
6-row 38"	4.4	8.7	13.0	17.4	21.7	26.0	30.4	34.8	39.1	43.4
8-row 30"	4.1	8.3	12.4	16.5	20.6	24.8	28.9	33.0	37.1	41.3

The above chart is for planters equipped with contact drive. This chart is based on average wheel slippage and liquid viscosities.

Measure and weigh one gallon of actual fertilizer solution to determine exact application rates. This chart was calculated based on a solution weighing 10 pounds per gallon.

IMPORTANT: Fertilizer application rates can vary from the above chart. To prevent application miscalculation, make field checks to be sure you are applying fertilizer to all rows at the desired rate.

NOTE: Flow to all rows should be checked periodically. If one or more lines are plugged, the desired rate will be delivered to the remaining rows keeping total application rate at desired rate.

FIELD CHECK

To check the exact number of gallons your fertilizer attachment will actually deliver on 30" row spacing, proceed as follows:

1. Remove the hose from one of the fertilizer openers and insert it into a collection container that has been secured to the planter frame.
2. Engage the fertilizer attachment and drive forward for 174'.
3. Measure the fluid ounces caught in the container and multiply that amount by 100.
4. Divide that amount by 128.
5. The result will be the gallons of fertilizer delivered per acre when planting in 30" rows. Rinse the collection container and repeat test on other rows if necessary. To convert this delivery rate for wider rows, multiply by the following conversion factors:

For 36" rows, multiply by .83 by result

For 38" rows, multiply by .79 by result

LIQUID FERTILIZER

Pull-Type Planters

TROUBLE SHOOTING

PROBLEM:

Pump Hard or impossible to Prime.

POSSIBLE CAUSE:

Valves fouled or in wrong place.	Inspect and clean valves.
Air leak in suction line	Repair Leak
Pump is set too low	Adjust Pump Setting
Packing washers are worn out	Replace.

PROBLEM:

Low Metering.

POSSIBLE CAUSE:

Valves fouled or in wrong place.	Inspect and clean valves.
Air leak in suction line	Repair Leak
Pump is set too low	Adjust Pump Setting
Broken valve spring	Replace.

PROBLEM:

Over Metering.

POSSIBLE CAUSE:

Improper rate setting	Adjust Pump Setting
Trash is under valves	Inspect and clean valves
Broken discharge valve spring	Replace.

PROBLEM:

Leaks Through when Stopped.

POSSIBLE CAUSE:

Trash is under valves	Inspect and clean valves
Broken discharge valve spring	Replace.

PROBLEM:

Fertilizer Solution leaking under stuffing box

POSSIBLE CAUSE:

Packing washers are worn out	Replace.
------------------------------	----------

PROBLEM:

Pump is using excessive Oil

POSSIBLE CAUSE:

Oil seals or o-ring worn and leaking	Replace.
--------------------------------------	----------

PROBLEM:

Pump operates noisily

POSSIBLE CAUSE:

Crankcase components worn excessively	Inspect and replace if necessary.
---------------------------------------	-----------------------------------

LIQUID FERTILIZER

Pull-Type Frame

SQUEEZE PUMP ASSEMBLY

ITEM PART No.	DESCRIPTION
1	JBL6C SQUEEZE PUMP 2 - 6 ROWS
	JBL8LC SQUEEZE PUMP 8 ROWS
	JBL12C SQUEEZE PUMP 12 ROWS
2	MPL1414 7/8" SPROCKET ADAPTER
3	F64286 SPRING PIN 5/16 X 2-1/4"
4	MPL1381 SPROCKET, 20 TOOTH
	MPL1383 SPROCKET, 8 TOOTH
	MPL1384 SPROCKET, 9 TOOTH
	MPL1385 SPROCKET, 10 TOOTH
	MPL1386 SPROCKET, 15 TOOTH
	MPL1387 SPROCKET, 22 TOOTH
	MPL1388 SPROCKET, 23 TOOTH
	MPL1389 SPROCKET, 26 TOOTH
5	MPL4414 7/8" SPROCKET RETAINER
6	KD2558 LYNCH PIN, 1/4"
7	KD2734-08 SLEEVE, 1 1/4" X 5/8"
8	KA7336 IDLER W/SPROCKETS
	KD7426 SPROCKET, 12 TOOTH
	KD1026 SLEEVE, 1 3/16"
	K10210 WASHER, 3/8" USS
	K10229 LOCK WASHER, 3/8"
	K10047 HEX BOLT, 3/8-16 X 1 3/4"
9	K11100 SCREW, 1/2-20 X 1/2"
	K10227 LOCK WASHER, 1/4"
	K10209 WASHER, 1/4" USS
10	G169A2040 CHAIN, #A2040
	G171A2040 CONNECTOR LINK, #A2040
	G172A2040 OFFSET LINK, #A2040
11	KA2354 ADAPTER
12	KA2355 LOCK COLLAR
13	K3400-01 FLANGETTE
14	K2100-03 BEARING
15	K10303 CARRIAGE BOLT 5/16-18 X 1
	K10232 LOCK WASHER 5/16"
	K10106 HEX NUT 5/16-18
16	K4200 FERTILIZER HOSE 1 1/4"
	HC-024 HOSE CLAMP
17	KD15685 CLAMP

ITEM PART No.	DESCRIPTION
18	K10017 HEX BOLT, 1/2-13 X 1 1/2"
	K10228 LOCK WASHER, 1/2"
	K10102 HEX NUT, 1/2-13
19	KD5857 SPRING
20	KD5988 SHAFT, 36" (4 & 6 ROW)
	KD5990 SHAFT, 74" (8 ROW)
21	KD3839 COUPLER, 2"
22	K10460 COTTER PIN, 1/4" X 2"
23	K10602 SPRING PIN, 1/4" X 1 1/2"
24	KD14431 HANDLE
25	KD14413 TORSION SPRING, L.H.
26	KD14430 RELEASE COLLAR, GOLD, R.H.
27	KA5229 SPROCKET STORAGE ROD
28	KD6165 PLATE, 8 ROW PUMP
29	K10004 HEX BOLT, 3/8-16 X 1 1/4"
	K10210 WASHER, 3/8" USS
	K10229 LOCK WASHER, 3/8"
	K10101 HEX NUT, 3/8-16
30	K11078 COVER
31	KD14432 SLEEVE, 1 1/4"
32	K11075 SNAP RING, 7/8"
33	K10496 SNAP RING, 1 1/2"
34	KD14427 SHAFT, 4 7/8"
	K1K378 WRENCH REPLACEMENT KIT (#7, 9, 24-26, and 32-36)