

TABLE OF CONTENTS

1. SAFETY

2. PREPARATION

3. FRAME

4. TRANSMISSION

5. DRIVE

6. ROW UNIT

7. OPTIONAL EQUIPMENT

GEARBOX

5" x 5" Mounted Frame

SETTINGS

Three different assemblies are possible for the standard gearbox.

1. Normal assembly for planters with an even number of rows and inter-row spacing of 18" or more.
2. Offset assembly, for planters with an odd number of rows and inter-row spacing of less than 18". The gearbox is then mounted on the left and as close as possible to the central metering unit. To do so, remove one of the bearing brackets ④ which support the hexagonal shaft.
3. Assembly for planters with 14"-15" inter-row spacing. Remove the 2 bearing brackets ④. A special gearbox model is supplied for planters with narrow 10"-12" inter-row spacing.

The standard gearbox consists of a changeable upper cluster fitted with six sprockets (two 3-sprocket clusters) and a lower fixed 3-sprocket cluster. This allows for 16 different gear ratios. The following gearbox chart indicates the distances possible for each distribution disc. A decal placed on the planter will provide the same information for on-the-spot reference.

To change the seed spacing, push the idler lever ①, lock its pawl ② then align to the proper sprocket combination. The small upper sprocket cluster is fitted with a bolt, ③ which should be tightened to avoid any sliding of the cluster.

The special narrow gearbox uses one upper 3-sprocket cluster.

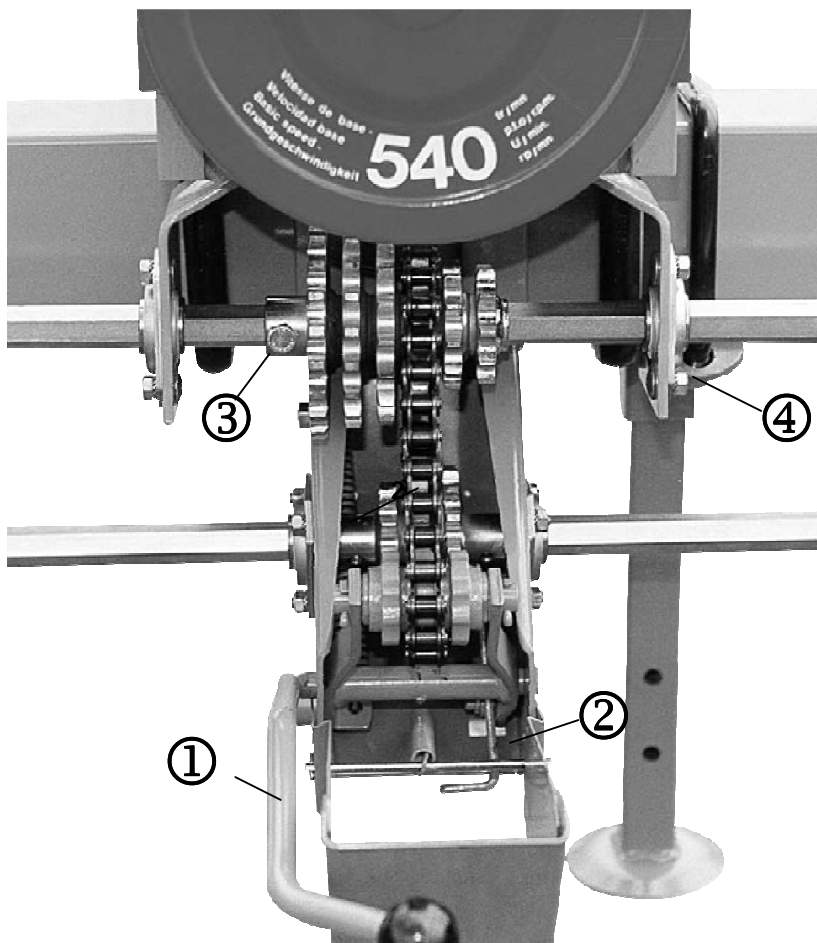

GEARBOX

5" x 5" Mounted Frame

DENSITIES - SEED POPULATION CHART

AVERAGE SEED SPACING ↓	← ROW SPACING →							
	10"	22"	26"	30"	34"	36"	38"	40"
1"	627,600	285,200	241,200	309,200	184,400	174,400	165,000	156,800
2"	313,800	142,600	120,600	104,600	92,200	87,200	82,500	78,400
2 3/4"	228,000	103,600	87,800	76,000	67,000	63,400	60,000	57,000
3 1/4"	193,200	87,800	74,200	64,400	56,800	53,600	50,800	48,200
3 1/2"	180,300	81,900	69,300	60,100	53,000	50,000	47,400	45,000
3 3/4"	167,400	76,034	64,300	55,800	49,200	46,500	44,000	41,800
4"	156,900	71,300	60,300	52,300	46,100	43,600	41,250	39,200
4 1/4"	147,600	67,000	56,800	49,200	43,400	41,000	38,800	36,900
4 1/2"	139,500	63,400	53,600	46,500	41,000	38,700	36,700	34,850
5"	125,400	57,000	48,250	41,800	36,900	34,850	33,000	31,400
5 1/2"	114,000	51,800	43,900	38,000	33,500	31,700	30,000	28,500
6"	104,550	47,500	40,200	34,850	30,750	29,000	27,500	26,100
6 1/2"	96,600	43,900	37,100	32,200	28,400	26,800	25,400	24,100
7"	90,150	40,950	34,650	30,050	26,500	25,000	23,700	22,500
7 1/2"	83,700	38,000	32,200	27,900	24,600	23,200	22,000	20,900
8"	78,750	35,750	30,300	26,250	23,150	21,850	20,700	19,675
8 1/2"	73,800	33,500	28,400	24,600	21,700	20,500	19,400	18,450
9"	69,900	31,750	26,900	23,300	20,550	19,425	18,387	17,475
9 1/2"	66,000	30,000	25,400	22,000	19,400	18,350	17,375	16,500
10"	62,850	28,575	24,200	20,950	18,475	17,475	16,537	15,725
10 1/2"	59,700	27,150	23,000	19,900	17,550	16,600	15,700	14,950
11 1/2"	54,600	24,800	21,000	18,200	16,050	15,150	14,350	13,650
12"	52,275	23,750	20,100	17,425	15,375	14,500	13,750	13,050
13"	48,300	21,950	18,550	16,100	14,200	13,400	12,700	12,050
13 1/2"	46,689	21,213	19,163	15,563	13,725	12,950	12,275	11,650
14 1/2"	43,464	20,475	17,938	14,488	12,775	12,050	11,425	10,850

GEARBOX

5" x 5" Mounted Frame

PLANTING RATE CHART

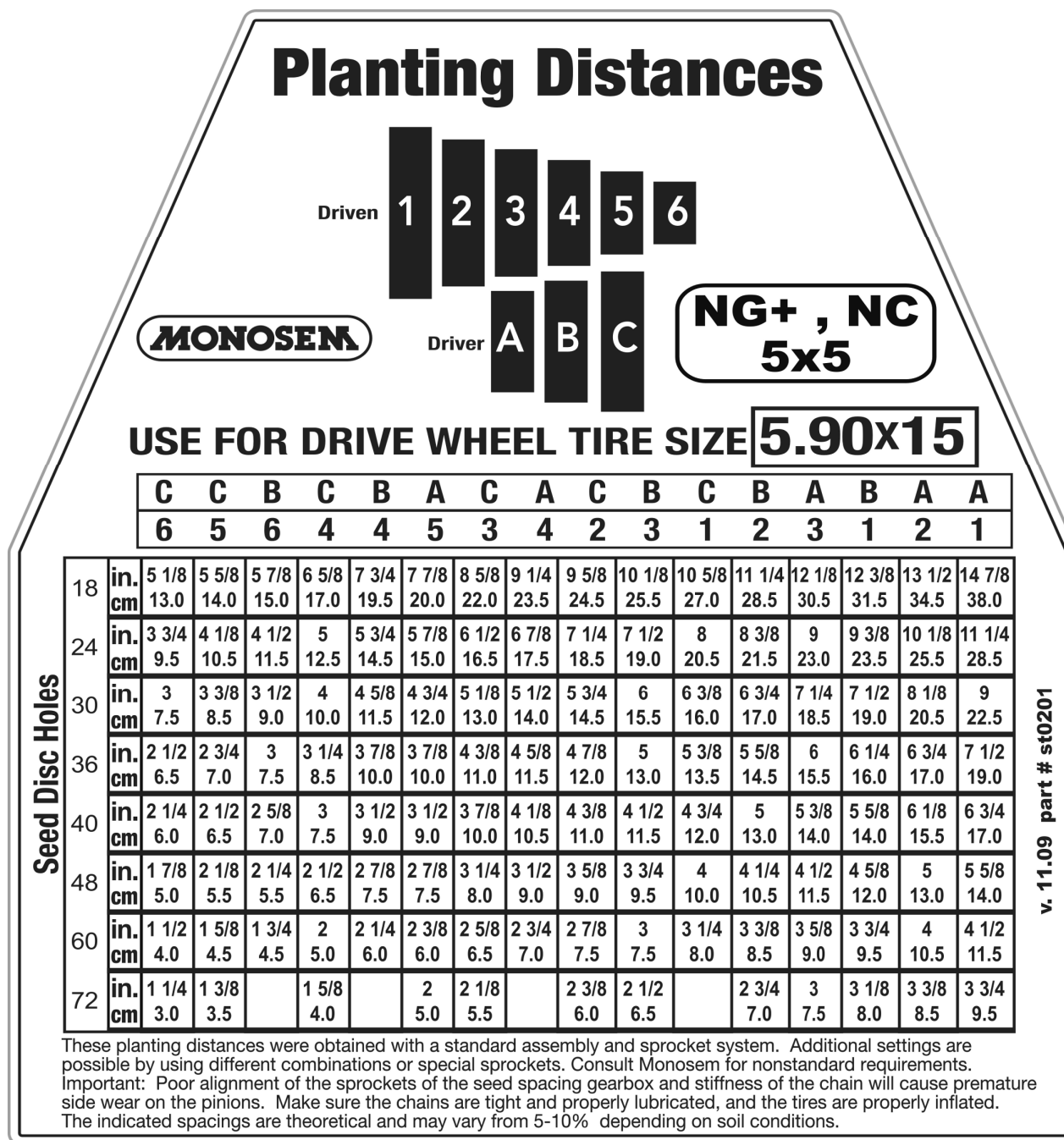

IMPORTANT! As of July 2008, The Tire on the Drive Wheel is 5.90 x 15.

Prior to July 2008, The Tire on the Drive Wheel was 5 x 15.

The size of the tire affects the planting distances.

The chart shown above reflects seed distances for the newer wheel, 5.9 x 15. This change is in effect as of July 2008.

Prior to July 2008 the planters had a drive wheel of 5 x 15.

To use the old chart (pre July 2008) with new tire (5.9 x 15), multiply distance on old chart by 1.07

To use the new chart (post July 2008) with old tire (5 x 15), divide distance on new chart (above) by 1.07

GEARBOX

5" x 5" Planter - 2008 and earlier

PLANTING DISTANCES

ARCHIVE SHEET, FOR USE WITH OLDER PLANTER, pre 2008

Planters before 2008

Gearbox Selection

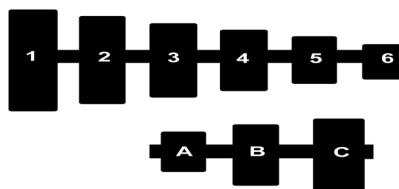

USE FOR DRIVE WHEEL TIRE SIZE 5" x 15"

Number of
Holes in the
Seed Disc



	C	C	B	C	B	A	C	A	C	B	C	B	A	B	A	A
	6	5	6	4	4	5	3	4	2	3	1	2	3	1	2	1
9 in	9 1/2	10 1/4	11	12 5/8	14	14 1/2	16 1/8	17 1/4	18	19	20	21 1/4	22 1/2	23 1/4	25 1/4	28
cm	24	26	28	32	35	37	41	44	46	48	51	54	57	59	64	71
18 in	4 3/4	5 1/8	5 1/2	6 5/16	7	7 1/4	8 1/16	8 5/8	9	9 1/2	10	10 5/8	11 1/4	11 5/8	12 5/8	14
cm	12	13	14	16	17 1/2	18 1/2	20 1/2	22	23	24	25 1/2	27	28 1/2	29 1/2	32	35 1/2
24 in	3 9/16	4	4 1/4	4 1/2	5 1/8	5 1/2	6 1/8	6 1/2	7	7 1/16	7 1/2	8	8 1/2	8 5/8	9 1/2	10 1/2
cm	9	10	10 1/2	11 1/2	13	14	15 1/2	16 1/2	17 1/2	18	19	20	21 1/2	22	24	26 1/2
30 in	2 3/4	3 1/8	3 3/8	3 3/4	4 1/4	4 3/8	4 3/4	5 1/8	5 1/2	5 3/4	6 1/16	6 5/16	6 3/4	7 1/16	7 3/4	8 1/2
cm	7	8	8 1/2	9 1/2	10 1/2	11	12	13	14	14 1/2	15	16	17	18	19 1/2	21 1/2
36 in	2 3/8	2 1/2	2 3/4	3 1/8	3 9/16	3 3/4	4	4 3/8	4 1/2	4 3/4	4 7/8	5 3/8	5 1/2	5 3/4	6 5/16	7 1/16
cm	6	6 1/2	7	8	9	9 1/2	10	11	11 1/2	12	12 1/2	13 1/2	14	14 1/2	16	18
40 in	2 1/8	2 3/8	2 1/2	2 3/4	3 1/8	3 3/8	3 9/16	4	4 1/4	4 3/8	4 1/2	4 3/4	5 1/8	5 3/8	6 1/16	6 1/2
cm	5 1/2	6	6 1/2	7	8	8 1/2	9	10	10 1/2	11	11 1/2	12	13	13 1/2	15	16 1/2
48 in	1 3/4	2	2 1/8	2 1/4	2 1/2	2 3/4	3	3 1/4	3 1/2		3 3/4	4	4 1/4	4 3/8	4 3/4	5 1/2
cm	4 1/2	5	5 1/4	5 3/4	6 1/2	7	7 3/4	8 1/4	8 3/4	9	9 1/2	10	10 3/4	11	12	13 1/4
60 in	1 3/8	1 5/8		1 3/4	2	2 1/8	2 3/8	2 1/2	2 3/4		2 7/8	3 1/8	3 3/8	3 9/16	4	4 3/8
cm	3 1/2	4		4 1/2	5	5 1/2	6	6 1/2	7		7 1/2	8	8 1/2	9	10	11
72 in	1 3/16		1 3/8	1 5/8	1 3/4		2	2 1/8		2 3/8	2 1/2		2 3/4	2 7/8	3 1/8	3 9/16
cm	3		3 1/2	4	4 1/2		5	5 1/2		6	6 1/2		7	7 1/2	8	9
120 in		3/4			1		1 3/16		1 3/8			1 5/8		1 3/4	2	2 1/8
cm		2			2 1/2		3		3 1/2			4		4 1/2	5	5 1/2

The indicated spacings are theoretical and may vary from 5-10% depending on soil conditions and tire pressure. Double check for proper seed population as soon as you start the planter and then at regular intervals. Important: Poor alignment of the sprockets of the seed spacing gearbox and stiffness of the chain will cause premature side wear on the pinions. Make sure the chains are tight and properly lubricated, and the tires are properly inflated.

GEARBOX

5" x 5" Mounted Frame

ASSEMBLY

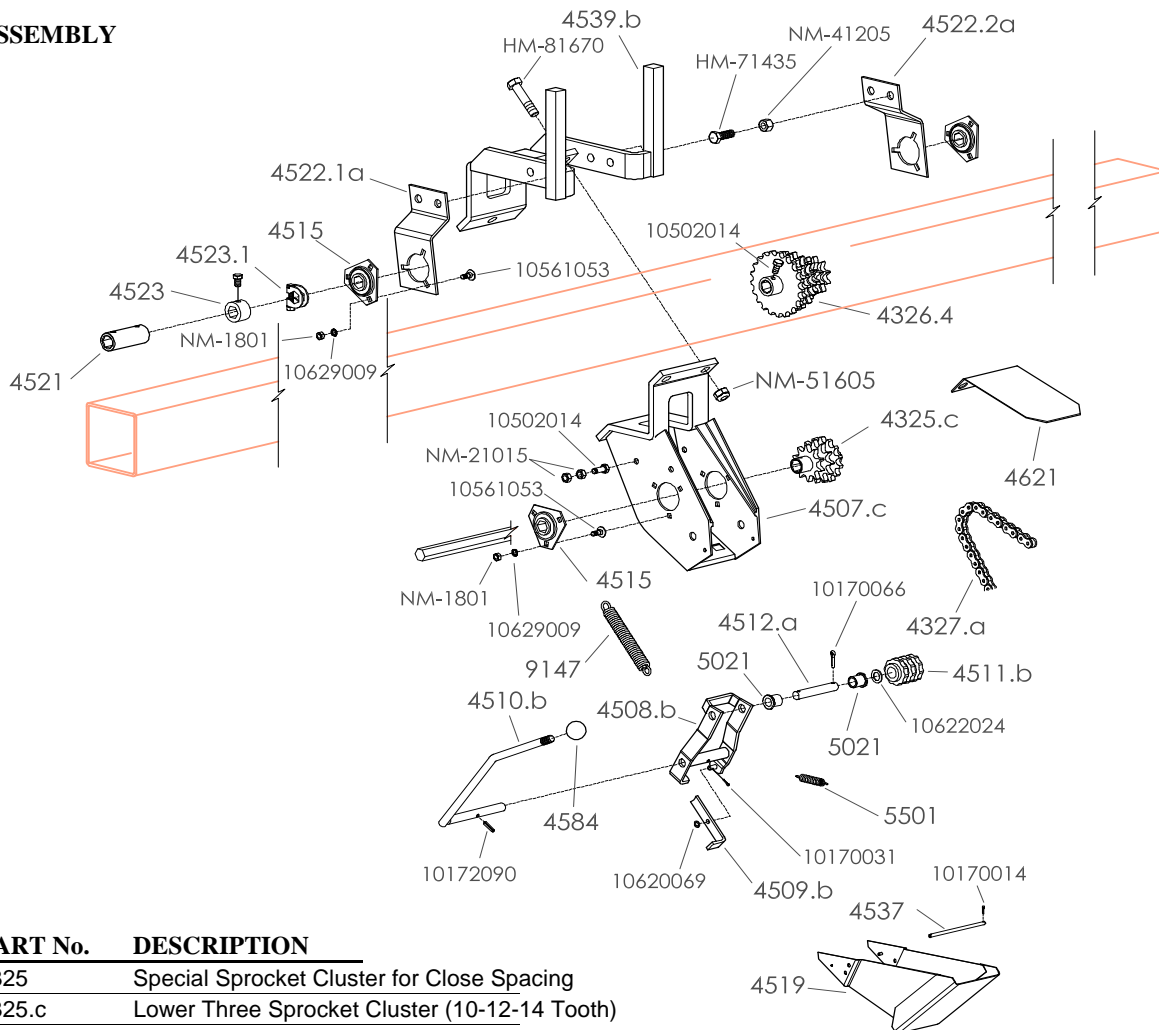

PART No. DESCRIPTION

4325	Special Sprocket Cluster for Close Spacing
4325.c	Lower Three Sprocket Cluster (10-12-14 Tooth)
4326.1d	Upper Three Sprocket Cluster (17-19-21 Tooth for Narrow Application)
4326.2d	Upper Three Sprocket Cluster (10-11-13 Tooth for Narrow Application)
4326	Standard 6-Tooth Upper Sprocket Cluster (10-11-13-17-19-21 Tooth)
4327.a	Drive Chain (13N, 36 links w/conn. Link)
4507	Gearbox Housing (for Narrow Spacing)
4507.c	Gearbox Housing
4508	Lever (for Narrow Spacing)
4508.b	Gearbox Lever
4509.b	Lever Lock
4510.b	Gearbox Handle
4511.b	Chain Tightener Roller (with 5021 Bushing)
4512.a	Pin
4515	Bearing Complete with Flangettes
4515	Bearing Only (205KRRB2, 7/8 Hex Bore)
4515	Flangettes (2)
4519	Gearbox Door
4522.1a	Left Support Bracket (for Hex Shaft)
4522.2a	Right Support Bracket (for Hex Shaft)
4537	Pin for Gearbox Door
4539.1b	Gearbox Mounting Bracket without Turbofan Stand
4539.b	Gearbox Mounting Bracket with Turbofan Stand

PART No. DESCRIPTION

4621	Shield, Gearbox
4584	Knob for Handle
5021	Bushing (Self Lubricating, B25)
5501	Spring, Gearbox Door
9147	Spring, for Tightening Drive Chain
10502014	Bolt, 10x20, on gear cluster #4326.4
10622024	Washer, 16.5x26x1
F21253	Carriage Bolt, 5/16-18-3/4
F36104	Hex Nut, 5/16
F33620	Lock Washer, 5/16